

# VANDERCOOK MANUAL

OPERATION MAINTENANCE

PARTS LIST

989-3310

SAN FRANCISCO No. 1





# Vandercook Manual

*Operation — Maintenance*  
*Parts List*

**Universal Hand**  
MODEL NO. \_\_\_\_\_

SERIAL NO. \_\_\_\_\_

Always be sure to give both the above Model and Serial Numbers when ordering parts or requesting information about this machine.



**VANDERCOOK**

**& SONS, INC.**

*Eastern Sales and Service*  
205 W. 34th St., New York 1, N. Y.  
Telephone BRyant 9-6270

*Main Office, Plant and Technical Center*  
3601 West Touhy Avenue Chicago 45, Illinois  
Telephone ROgers Park 1-2100

*Western Sales and Service*  
3156 Wilshire Blvd., Los Angeles 5, Calif.  
Telephone DUnkirk 8-9931



## INSTALLATION

Uncrate the press and remove all protective paper. Leave the press on its skids until it has been moved to its approximate location. Clean thoroughly, particularly all machined surfaces, using kerosene and rags.

Remove skids and set press on synthetic rubber pads furnished—one under each leg at feed board end and one under leg at end of press. Place a precision level on the bed, and level the press by putting metal shims under the rubber pads where necessary. It is very important that the bed of the press be absolutely level.

Bolt the feed board to the top of the leg, using the four hexagon head cap screws furnished.

## ELECTRICAL CONNECTIONS

Electrical connections should be made according to local code regulations - by an experienced electrician. Be sure that the ink drum rotates counterclockwise from the operator's side.

## LUBRICATION

### All Oil Holes

At least once a week. Use S.A.E. #20 Oil.

### Vibrator Worm

Keep covered with a petroleum jelly product such as vaseline.

### Vibrator Shaft

At least once a week. Use S.A.E. #20 Oil.

### Bed and Cylinder Bearers

Wipe bearers with slightly oiled rag daily.

### Cylinder Guide Plates

At least once a week, using S.A.E. #20 Oil.

### Under Rails

Both Under Rails should be wiped clean and well oiled daily.

\* \* \* \* \*

For further instructions on lubrication refer to repair parts sheets.



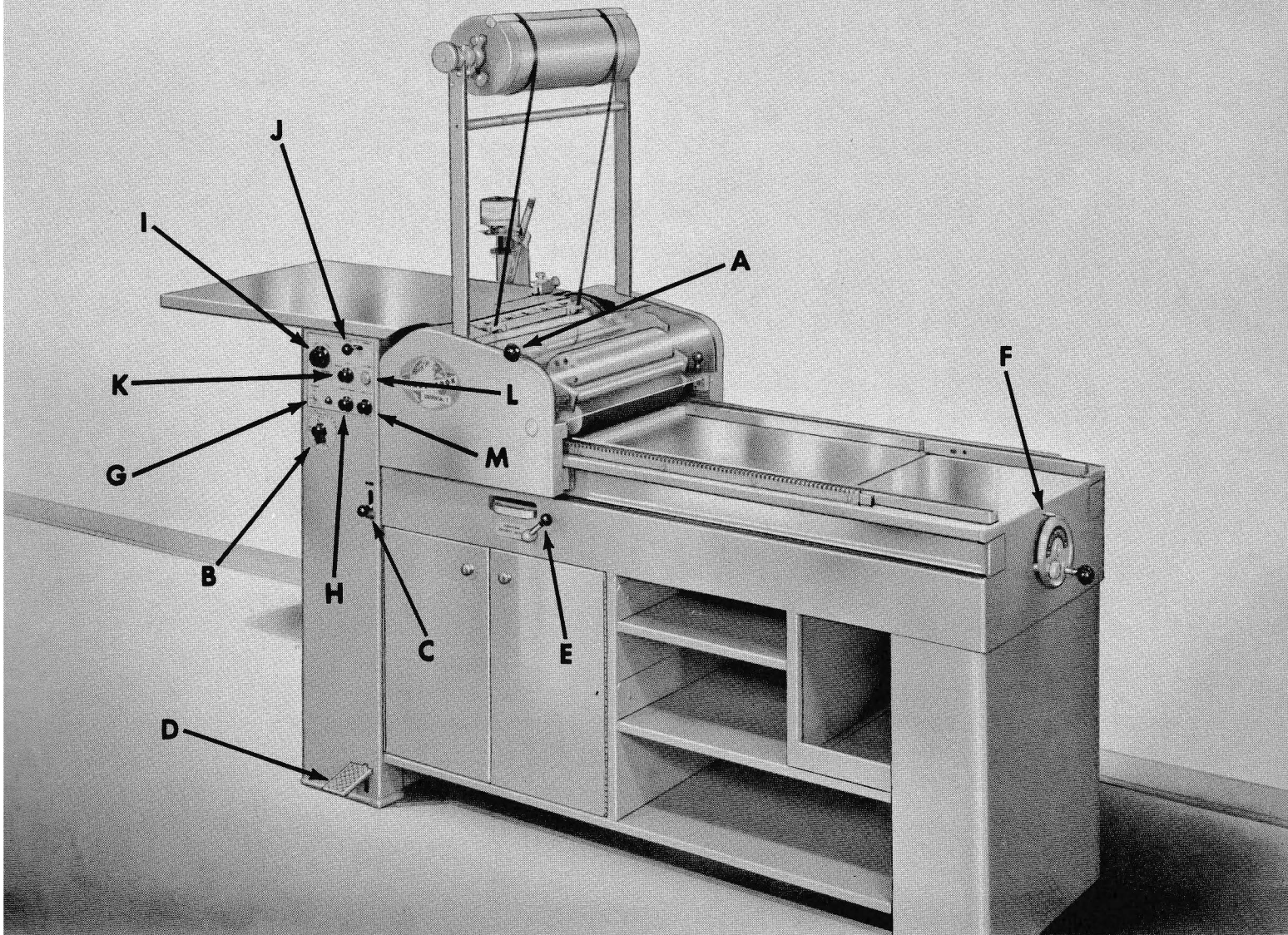

## CONTROLS

(Illustration 1)

### INKING ROLLER TRIP LEVER (A)

Lever "A" lifts form rollers and separates steel vibrator and rider from form rollers.

### INK FOUNTAIN CONTROL (B)

Lever "B" controls flow of ink from automatic ink fountain and trips distributor roller off ink drum.

### CYLINDER TRIP (C)

Cylinder is on trip when lever "C" is in top position. When gripper pedal "D" is depressed to feed a sheet, the cylinder trip lever will go to print position automatically and will remain in print position unless it is brought up to trip position again.

### GRIPPER PEDAL (D)

Pedal "D" opens the grippers. On hand driven presses, there is also an automatic gripper opener to open the grippers just before the cylinder reaches the feed board and to close the grippers during the last 1/4" travel of the cylinder toward the feed board.

### AUTOMATIC WASHUP LEVER (E)

Moving lever "E" to its lower position brings the washup doctor blade into contact with the motor driven ink drum.

### ADJUSTABLE BED HAND WHEEL (F)

Hand wheel "F" raises or lowers the bed through its range of .240". The dial near the open end of the bed gives the distance between the bed and the top of the bed bearers.

When raising or lowering the bed, be sure to allow for the back lash in the threads that occurs when changing the direction of the rotation of the hand wheel. Back lash is taken out by always finally turning the hand wheel in a counterclockwise direction when making an adjustment.

## CONTROLS FOR POWER DRIVEN PRESSES WITHOUT AUTOMATIC TAPE SHEET DELIVERY

### POWER SWITCH AND PILOT LIGHT (G)

Throwing toggle switch "G" to ON position starts ink drum motor and lights pilot to indicate press is ready to run.

### DYNAMIC BRAKE CONTROL (H)

Knob "H" controls the dynamic brake that stops the cylinder at both ends of its travel. It should be adjusted so that the cylinder comes to rest smoothly at the feed board end with grippers as close as possible to the edge of the feed board.

### SPEED CONTROL (I)

Knob "I" controls the speed of the travel of the cylinder (from 54 to 108 feet per minute).

CAUTION:

When using Power Grippers, it is essential that Manual Control Lever (J), or Selector Switch (K), are not moved when the cylinder is at the feed board, without waiting three seconds after the cylinder reaches the feed board. If Lever or Selector Switch are moved within the three-second period, the fuse may blow in the Power Gripper Circuit.

place at bottom between "Speed control (I) page and "Manual Control Lever (J)" page 6a 3



### MANUAL CONTROL LEVER (J)

When lever "J" is placed in the FORWARD position, cylinder carriage will move to open end of bed and automatically stop. Moving lever to the REVERSE position causes cylinder to return to feed board.

### ADDITIONAL CONTROLS FOR POWER DRIVEN PRESSES WITH AUTOMATIC TAPE SHEET DELIVERY

#### SELECTOR SWITCH (K)

With knob "K" set at MANUAL, the forward and back motion of the cylinder is controlled by lever "J" and the cylinder will automatically stop at either end of the bed. With knob "K" set at CYCLE, cylinder will make one complete cycle after the button "L" is pressed, as explained below. With knob "K" set at RUN and control lever "J" in forward position, the press will operate continuously until lever "J" is placed in OFF position. Also the power operated grippers will be placed in operation as explained below.

#### STARTING BUTTON (L)

With control lever "J" to FORWARD position and selector switch "K" turned to CYCLE, cylinder will make one complete cycle after operator presses starting button "L". Press may be stopped at any time by moving control lever "J" to OFF position.

### ADDITIONAL CONTROL FOR POWER DRIVEN PRESSES WITH AUTOMATIC TAPE SHEET DELIVERY AND POWER OPERATED GRIPPERS

#### FEEDING TIME CONTROL (M)

Knob "M" controls the length of time cylinder will remain at the feed board with grippers open to permit feeding a sheet (.5 to 2.5 seconds). To cause the grippers to become power operated, selector switch "K" is set at RUN position.



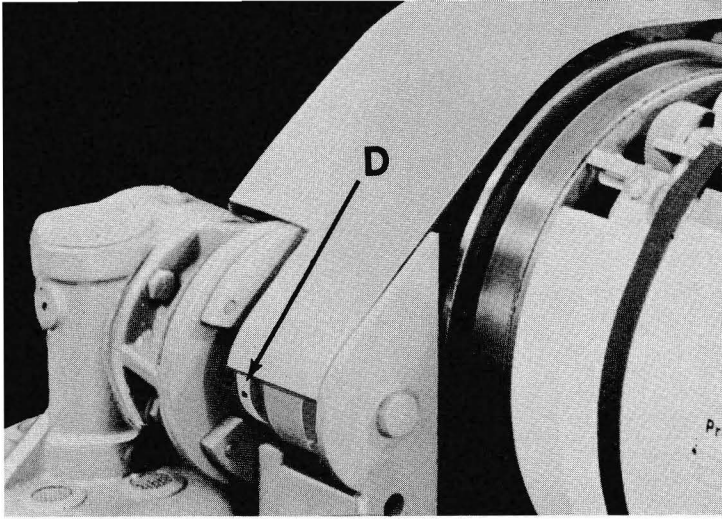

ILLUSTRATION 2

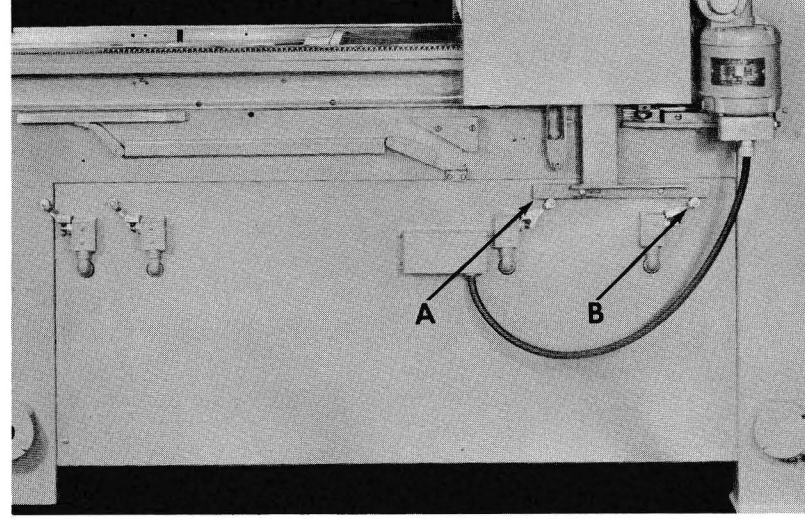

ILLUSTRATION 3

### CLUTCH DRIVE ADJUSTMENT

If the travel of the cylinder carriage (1) slows up, or (2) doesn't move at all with the drive motor turning, or (3) hits the bumpers too hard after all the cam adjustments have been made, a simple drive clutch adjustment is necessary, as follows:

- 1 - With press at slowest speed and on "impression," run cylinder to open end.
- 2 - Run cylinder back toward feed board until trip cam is engaged.
- 3 - Adjust clutch so that it holds just enough to drive cylinder past the trip cam.

Caution should be taken not to over-adjust the clutch drive, for too tight an adjustment will eliminate the safety feature provided in the clutch.

### ELECTRICAL CONTROL BOX

The Electrical Control Box is located behind the hinged door in the leg under the feed board. Prolonged periods of excessive jogging or stalling-out of cylinder carriage due to a jam-up may blow one of the four fuses located inside the control box (on presses with Power Operated Grippers there will be five fuses - the one to the right will be for the gripper solenoid).

The ink drum gear motor has inherent overheating protection. If it is stalled-out for some abnormal reason, it will resume turning after a short pause.

### LIMIT SWITCH CAM ADJUSTMENTS

With the press inked up, cylinder on impression, and clutch properly adjusted, the cylinder carriage should stop  $1/16''$  to  $1/4''$  away from bumper at the open end of the press when speed control knob "I" and brake control knob "H" are set at center of their range (Illustration 1).

When cylinder carriage does not stop as stated above, adjust cam "A" (Illustration 3) to the right to bring the cylinder closer to the bumper - and to the left if it is hitting too hard.

In cases where the cylinder carriage hits too hard on returning to the feed board, adjust cam "B" (Illustration 3) to the right. If it does not return so that the gripper bar is approximately  $1-5/16''$  away from the feed board, then adjust cam "B" to the left.



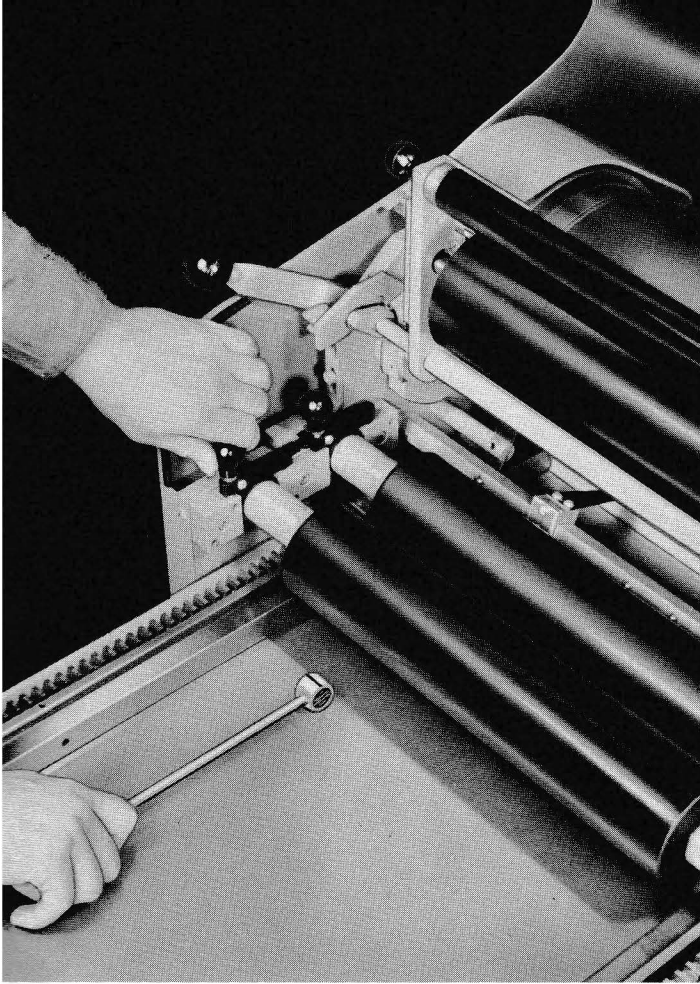

ILLUSTRATION 4

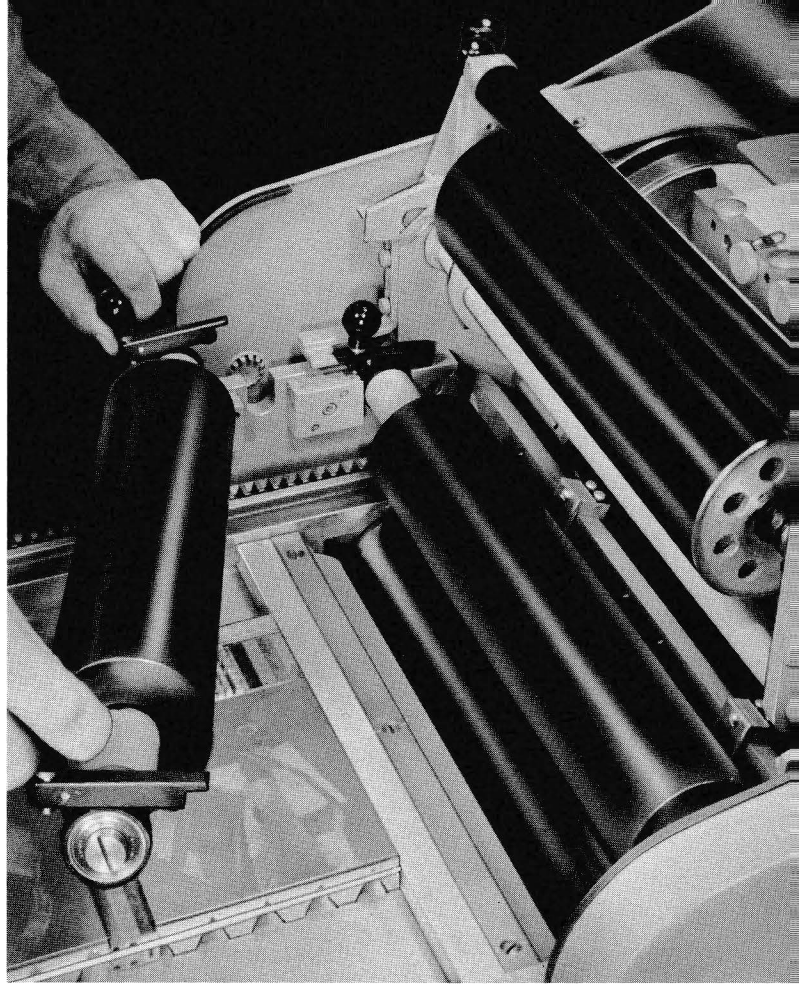

ILLUSTRATION 5

ILLUSTRATION 6

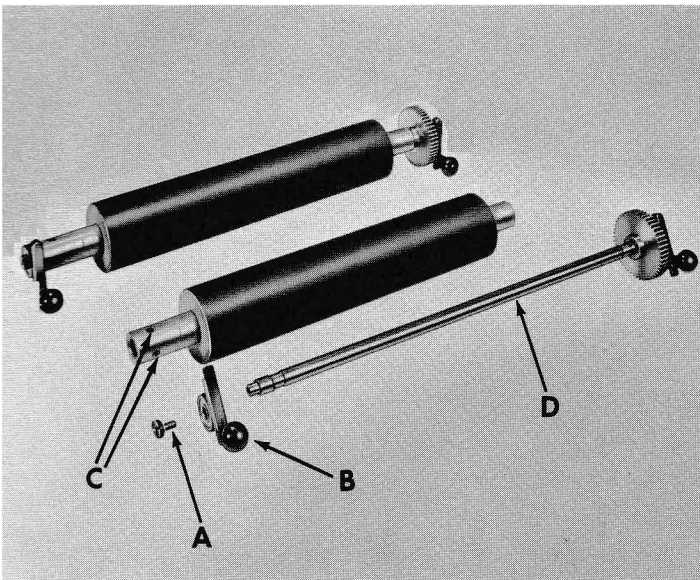

ILLUSTRATION 7





## CYLINDER PACKING

The cylinder bearers are .040" higher than the body of the cylinder. On presses equipped with adjustable bed, it is possible to use a standard packing consisting of six .006" treated manila tympan sheets.

The correct impression for paper up to .010" in thickness is obtained by adjusting the bed. When printing on thicker material, some of the cylinder packing should be removed.

On presses not equipped with adjustable bed, the cylinder packing plus the stock to be printed on should be approximately .003" over the cylinder bearers.

To change packing, move cylinder to center of bed (on trip, if there is a form or plate on the bed) so that reel rod is in up position. Unlatch reel rod ratchet with wrench provided and loosen drawsheet from reel rod. With left hand, grasp packing and, as cylinder is returned to feed board, lay packing on feed board.

To change the drawsheet, loosen the filister head screws in the clamp bar. Unless overlays are used, only the drawsheet is held by this bar.

When moving cylinder to center of bed to secure packing, hold packing in position by smoothing out with left hand. Insert flap of drawsheet all the way into the slot in reel rod, and then draw tight by turning reel rod counterclockwise with wrench supplied. Be sure packing is tight to cylinder at both sides of gripper edge. There is sufficient side play in the reel rod to correct a small amount of unevenness in packing.

## THE INKING SYSTEM

The basic inking system on the Vandercook Universal Test Presses consists of two 3" form rollers, one 3.891" vibrator and one 1.250" rider.

Presses equipped with power ink distribution have a 5.437" ink drum driven by a 1/12 h.p. gear motor. Presses equipped with automatic ink feed have a 3" synthetic vibrating roller in contact with the ink drum and a 1" steel transfer roller.

## ADJUSTING FORM ROLLERS

(Illustration 4)

Form rollers are adjusted by turning the black knobs to the right to raise the rollers, and to the left to lower them.

The adjusting knobs can be made to turn tighter or looser by means of the clamping screws on the side of the form roller bearing assembly.

When using synthetic form rollers, they should be adjusted to leave a streak  $1/16$ " on the Vandercook Nuway Roller Setting Gauge, as shown in Illustration 4.

For glue composition rollers, a  $1/8$ " wide streak is better to properly ink plate or form. There are no other adjustments to make in the inking system.

### CHANGING FORM ROLLERS

(Illustration 5)

Form rollers can be changed in a few seconds by merely lifting out the assembly of rollers, ball bearings and adjusting mechanism, as shown in Illustration 5.

It is an excellent idea to have at least one extra set of rollers equipped with bearings, adjusting mechanism and driving gear.

### ASSEMBLING NEW ROLLERS

(Illustration 6)

To transfer the bearings, adjusting mechanism and driving gear to another set of rollers, proceed as shown in Illustration 6. First, unscrew slotted screw "A" (operator's side) and remove bearing and adjusting mechanism "B". Next, loosen the two set screws "C" and pull out shaft and gear assembly "D".

When new form rollers are placed in the press, the form roller surface ends should be in line to one another and also aligned with the steel rider. This is done to ensure a better automatic washup.

### AUTOMATIC WASHUP

Presses equipped with Power Ink Distribution have automatic washup as standard equipment. Plastic container is supplied for solvent.

To wash up press, bring nylon doctor blade "A" (Illustration 7) into contact with ink drum by moving lever "B" to the lower position. Apply solvent to steel rider roller, a small amount at a time, so that the inking system will continue to be driven by the motor driven drum.

Blotting paper pads may be used in tray (Illustration 7) to absorb ink and solvent. The nylon doctor blade should be wiped clean each time it is used - to prevent ink from accumulating. When ink is not wiped off regularly, it will dry on the nylon blade and prevent a thorough washup.

## CARE OF FORM ROLLERS

To get the maximum life and performance out of form rollers, they should be kept clean when not in use.

It is a wise policy not to allow ink to dry or remain overnight on form rollers, but to clean them thoroughly at the end of each shift and more frequently if possible. Ink that is allowed to dry will form a glaze on the rollers, which results in inadequate inking.

When press is idle, form rollers should be raised by means of the hand lever provided for this purpose. Raising the rollers in this manner prevents them from being marked by contact with the steel distributors or ink drum.

### Operation of the VANDERCOOK INK FOUNTAIN

This ink fountain, as illustrated below, is available as optional equipment. The power driven ink drum appears on the extreme right. Arrow 1 identifies the ductor vibrator, Arrow 2 the fountain roller, Arrow 3 the fountain blade, Arrow 4 the fountain blade adjusting screws, and Arrow 5 the ink fountain control. For quick washup, the fountain blade can easily be withdrawn without the use of tools. Operation of the Vandercook Ink Fountain is illustrated and described on the reverse side.

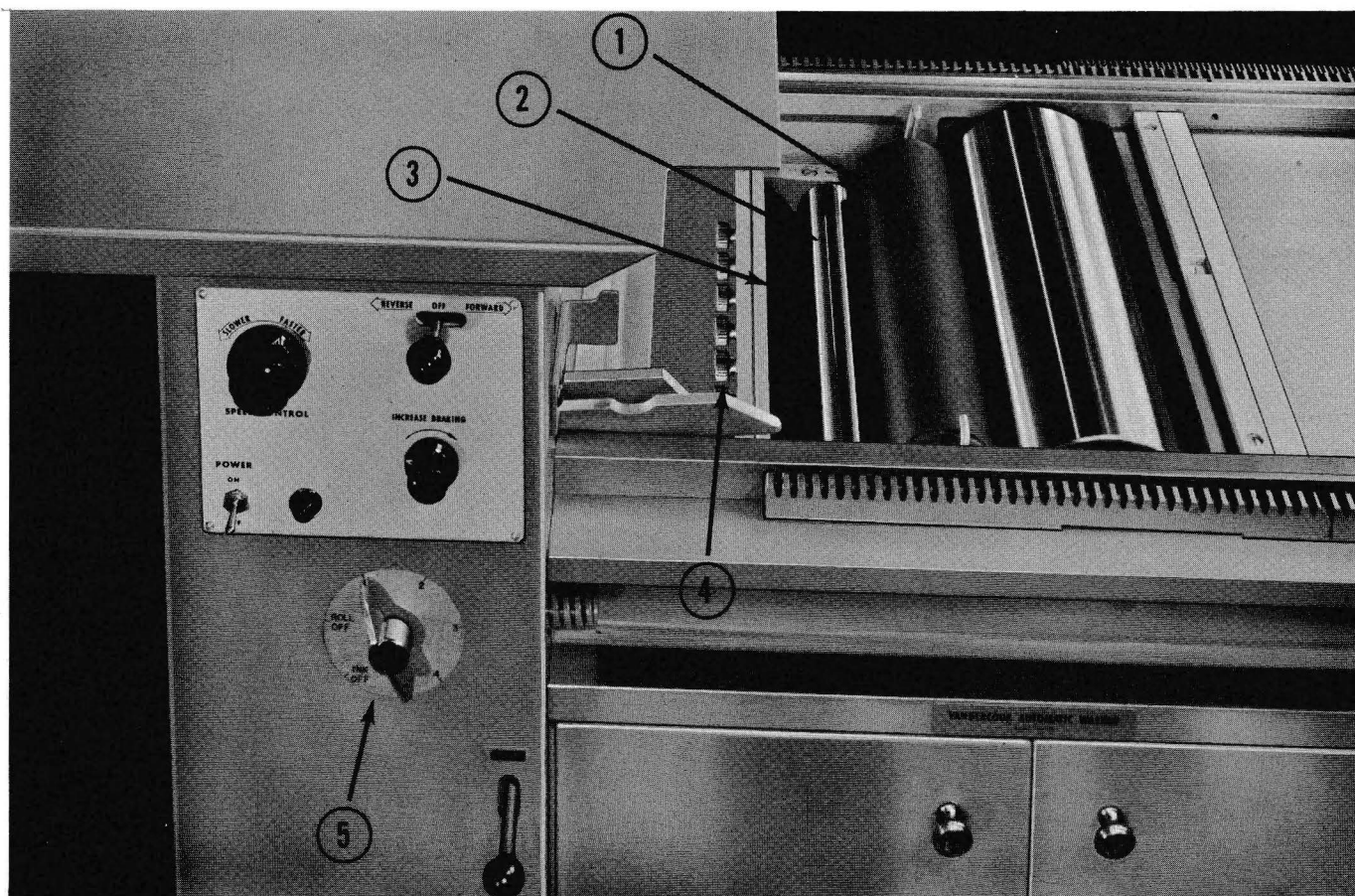

## OPERATION OF VANDERCOOK INK FOUNTAIN

ROLL  
OFF

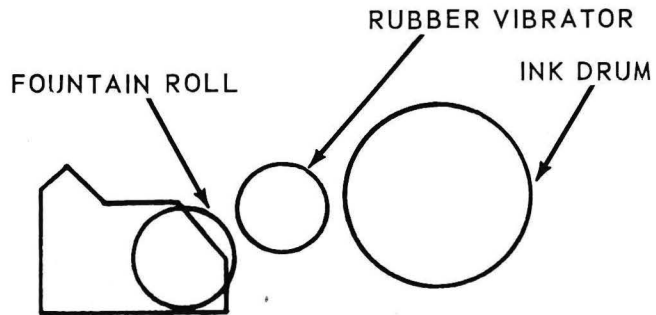
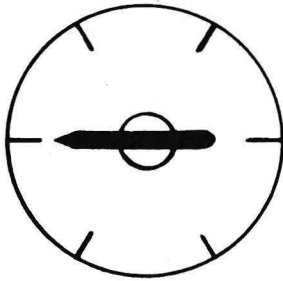

WITH POINTER AT "ROLL OFF" POSITION, FOUNTAIN ROLL DOES NOT INDEX, & RUBBER VIBRATOR DOES NOT COME IN CONTACT WITH INK DRUM. RUBBER VIBRATOR DOES MOMENTARILY CONTACT FOUNTAIN ROLL AS CARRIAGE NEARS & LEAVES FEED BOARD END OF MACHINE.

INK  
OFF

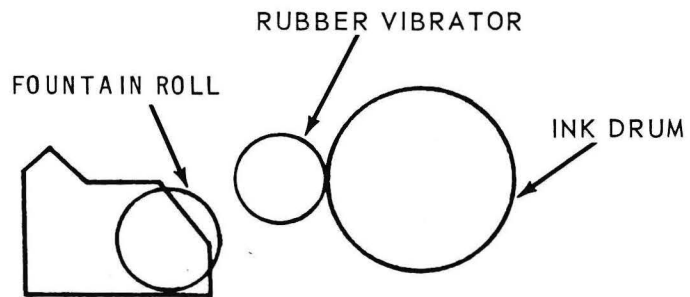
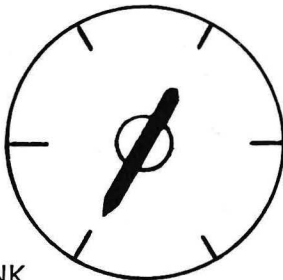

WITH POINTER AT "INK OFF" POSITION, FOUNTAIN ROLL DOES NOT INDEX & RUBBER VIBRATOR IS IN CONSTANT CONTACT WITH INK DRUM. USE THIS POSITION FOR WASHUP.

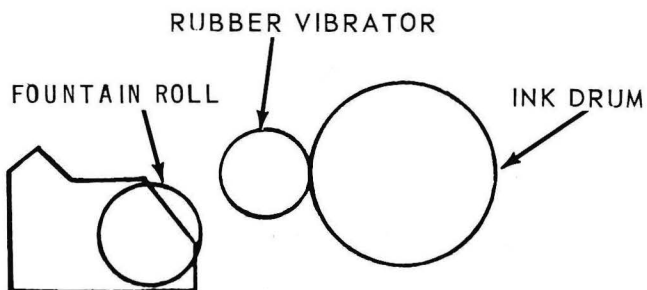
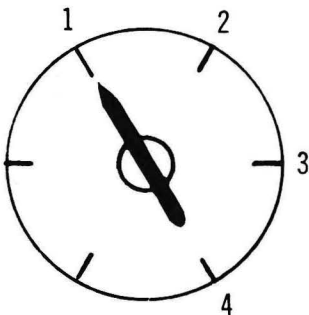

WITH POINTER AT "1", "2", "3" OR "4" POSITION RUBBER VIBRATOR OSCILLATES BETWEEN INK DRUM & FOUNTAIN ROLL. FOUNTAIN ROLL INDEXES IN INCREMENTS OF  $7\frac{1}{2}^\circ$  FOR EACH POSITION WHEN ACTUATED BY CARRIAGE.

**AUTOMATIC TAPE SHEET DELIVERY**  
**AND AUTOMATIC FRISKET**

On presses equipped with the Automatic Tape Sheet Delivery, the printed sheet is automatically brought back to the operator, as shown in Illustrations 10, 11, 12 and 13. Sliding clamps are provided to secure tapes to gripper bar. Tapes should be adjusted to clear sides of form.

When sheet delivery tapes are not in use, the tape clamp bar is placed in the upper position (Illustration 14). A light pull on the tape clamp bar will release the spring catches that hold the bar to the gripper assembly.

In case the tapes alone do not properly bring the printed sheet back to the feed board, a fly sheet should be used. For this purpose, one of the undersheets in the packing is removed and used as a fly sheet. The fly sheet is cut out as shown in Illustration 15 in order for it to clear the side and end guides. The tabs on the end of the fly sheet are inserted under the heads of the slotted screws located on top of the gripper bar (Illustration 16). The sheet to be printed is fed to the grippers on top of the fly sheet.

When it is desired to automatically frisket out dead metal on original photoengravings, the tape clamp bar on the drum is removed and replaced with the frisket paper, attaching it to the drum with masking tape. Also, the tape clamp bar attached to the gripper bar (with the two sliding clamps) is then replaced with the paper clamp bar to hold the frisket paper. Both of these bars are of the snap-on type. Illustration 17 shows the Automatic Frisket in position ready for operation. Frisket may be cut without disconnecting frisket paper from the paper clamp bar by feeding a sheet of card stock (with cylinder tripped) and cutting the frisket against the cylinder. The square openings necessary for clearing the paper guides should be cut before inserting frisket paper into clamp bar, using the template furnished.

When automatic frisket is not in use, the frisket clamp bar is placed in the same upper position as is used for the delivery tapes (Illustration 14).

**CAUTION**

When using the Automatic Tape Sheet Delivery, the cylinder sheet fingers are not required - and they must be adjusted to the positions nearest the cylinder bearers. If sheet fingers are left in the printing area when using the Automatic Tape Sheet Delivery, they may buckle the sheet on its return travel, which may cause the fingers to hit the form.



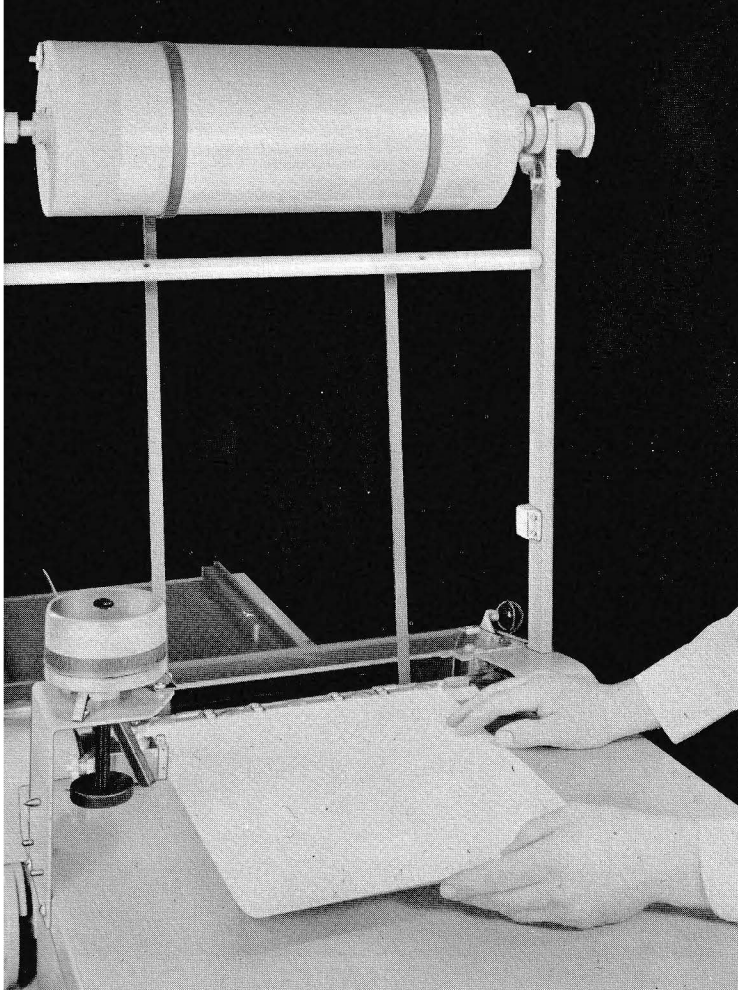

ILLUSTRATION 10

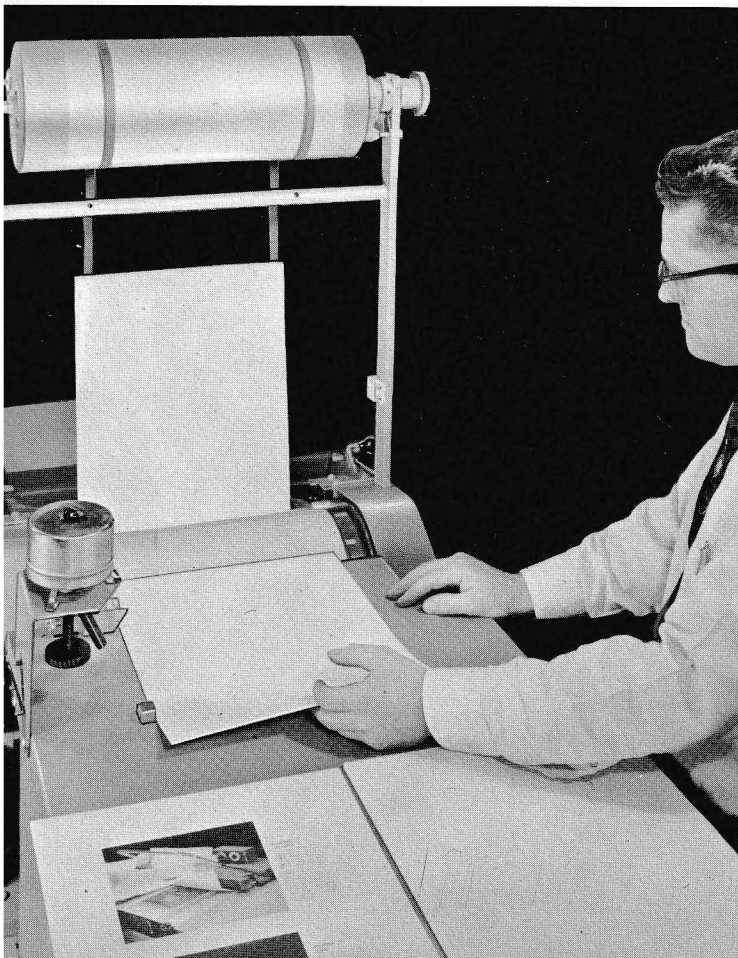

ILLUSTRATION 11

ILLUSTRATION 12

ILLUSTRATION 13

ITEM 598



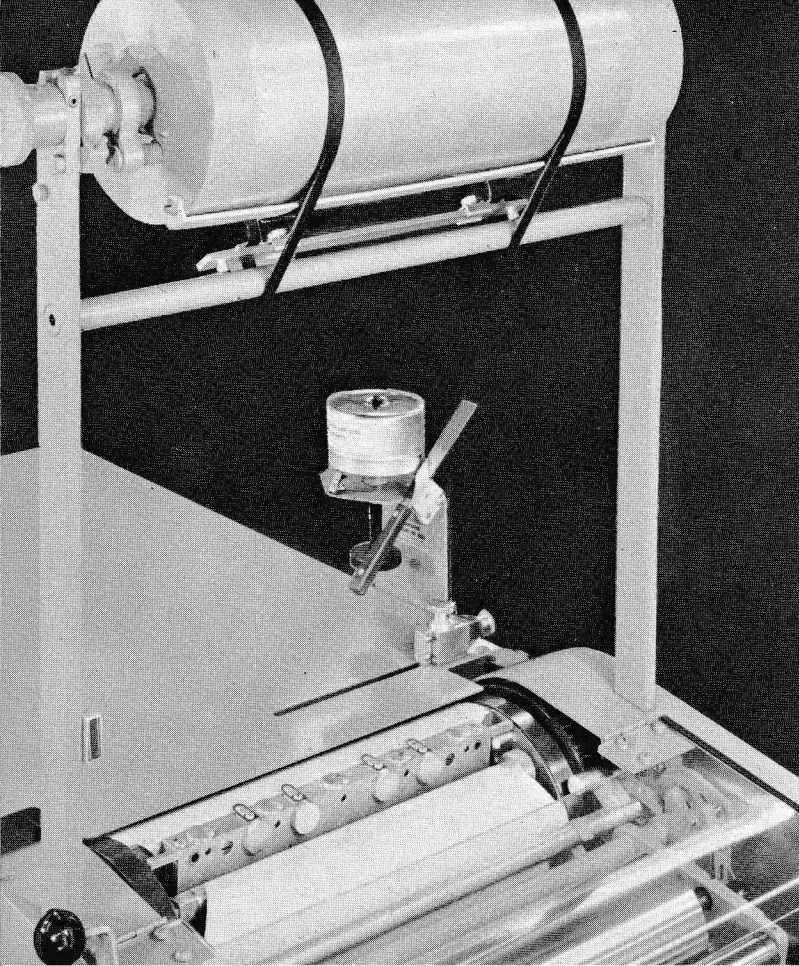

ILLUSTRATION 14

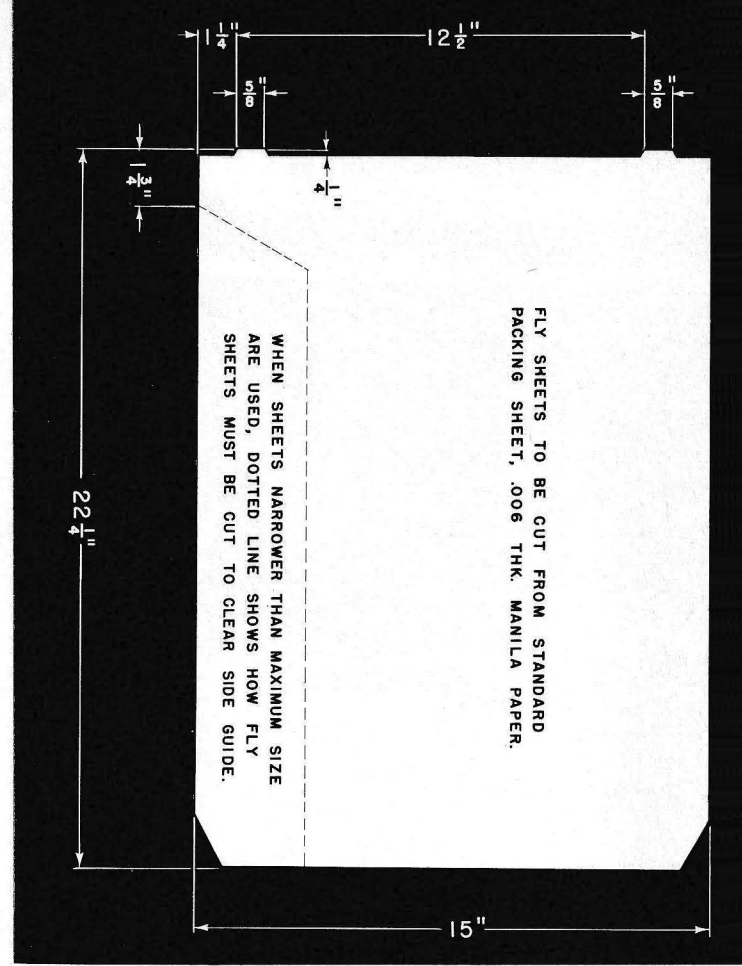

ILLUSTRATION 15

ILLUSTRATION 16

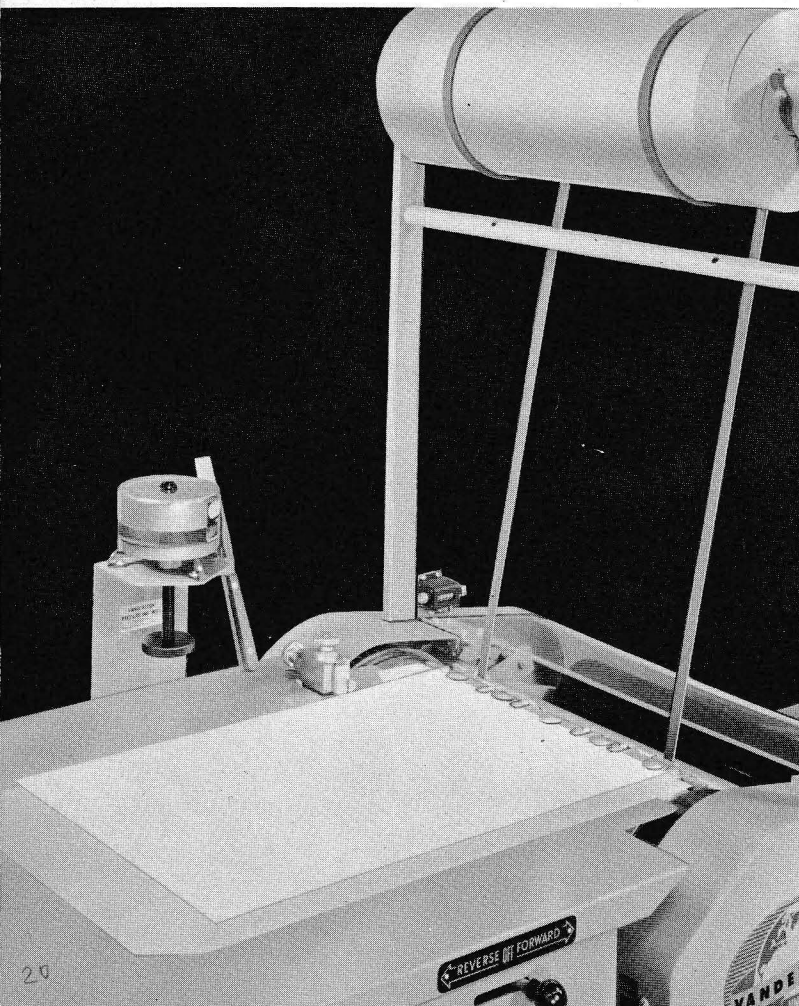
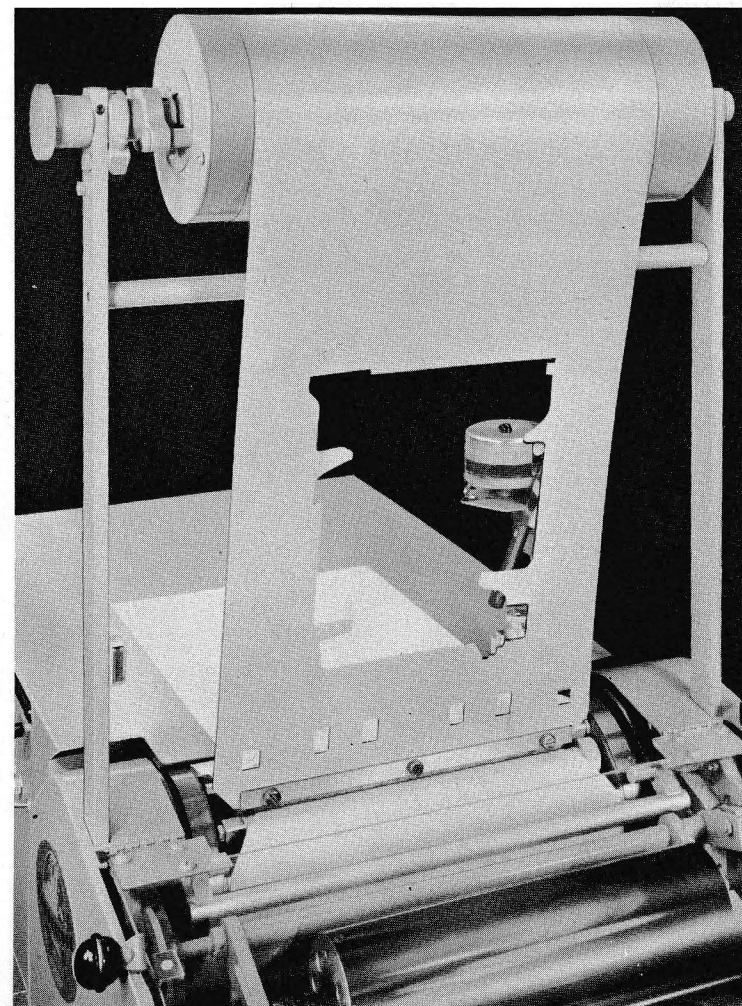

ILLUSTRATION 17



## TRANSPARENT PROOFS

Presses with Transparency Equipment can be used for producing transparent proofs printed on one side or on both sides. When printing on both sides of the acetate, a multiple impression (two or three) is taken on a standard .035" offset blanket before feeding the acetate sheet. For transparent proofs printed on one side, the Vandercook Papercote Blanket is used and the operation of printing on the blanket is eliminated. Two-sided transparencies are preferred by some plants to help overcome defects in forms - and, for extra opacity, these transparencies are then usually dusted with lamp black. For either one or two-sided transparencies, acetate is fed as follows:

### STEP ONE

A sheet of acetate is fed to the grippers, as shown in Illustration 18. In this operation, care must be taken that the sheet being fed is neither wrinkled nor bunched along the gripper edge.

### STEP TWO

The acetate is now carefully smoothed out on the feed board, and the pad attached to frame brought down against the cylinder packing, as shown in Illustration 18.

### STEP THREE

Next, pressing down lightly on the handle of the pad frame, as pictured in Illustration 19, the operator moves the cylinder forward to take an impression on the acetate. When the entire sheet has been fed to the cylinder, the frame is released, and the springs provided will raise it out of the way to avoid contact with the gripper bar and impression cylinder.

The cylinder is now returned to the feed board, and another impression made in order to obtain the maximum opacity. A third impression is sometimes advisable. These multiple impressions are possible because the blanket will hold the acetate securely in place. After the final impression, the acetate is peeled off as the cylinder is returned to the feed board.

In order to obtain best results, the form or plate should always be locked either in a chase or on the bed of the press. Pulling proofs of type on a galley is never recommended since galleys are not sufficiently accurate to obtain quality results. For the same reason, best results cannot be obtained if the press is equipped with a galley thickness bed plate.



ILLUSTRATION 18

ILLUSTRATION 19



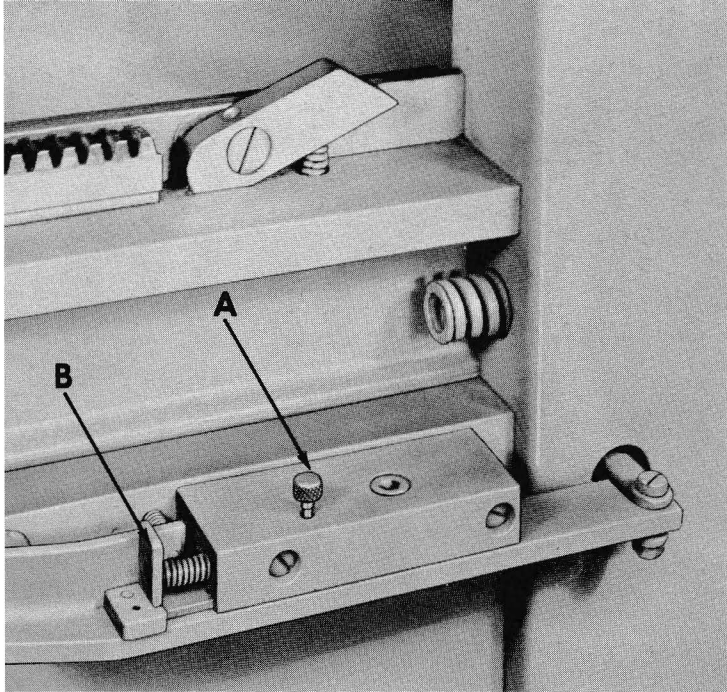

ILLUSTRATION 21

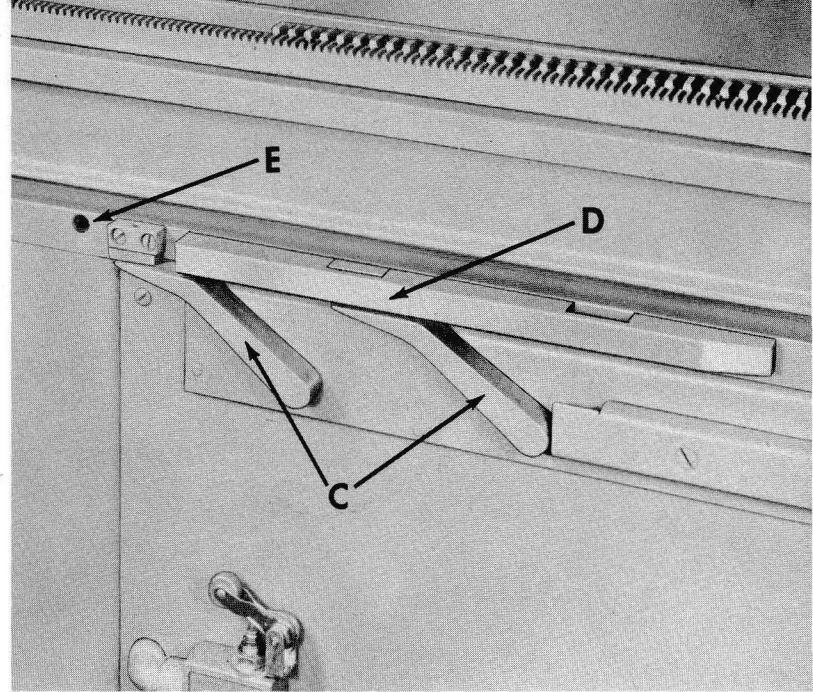

ILLUSTRATION 22

### GRIPPER OPERATION

Automatic gripper operation is accomplished on hand presses when the knurled pin "A", shown in illustration 21, is pulled all the way up. With the pin in this position, the gripper opener automatically opens the grippers as the cylinder carriage nears the feed board. Then, as cylinder carriage is moved back farther, the pressure exerted against the bumper springs will close the grippers. When cylinder is at the feed board end, the grippers can also be opened by means of the foot pedal. Grippers will open automatically to release proof at the end of the press.

Hand operated Vandercook Universal I Presses have two cylinder trip cams ("C" shown in Illustration 22) which permit either a short or long printing stroke. When short printing stroke is used, place gripper opener cam "D" in position, as shown in Illustration 22. If long printing stroke is used, place cam "D" in the rear position, using dowel pin hole "E".

When making transparent impressions, cam "D" should be removed from the press so that the grippers do not open at the foot end. Also, to prevent grippers from opening automatically when cylinder carriage nears the feed board, latch "B" (Illustration 21) should be pushed in all the way so that knurled pin "A" will drop down and hold it in place.



X-18274 SPRING PIN 2 REQ.  
 X-18255 RELEASE PIN 2 REQ  
 BRS-4 SPRING 2 REQ.

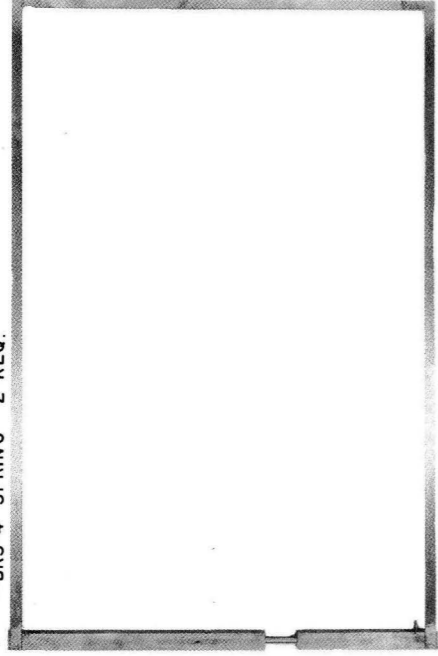

X-18566 FRISKET FRAME COMPLETE (UNIV. I)  
 X-18061 FRISKET FRAME COMPLETE (UNIV. III)

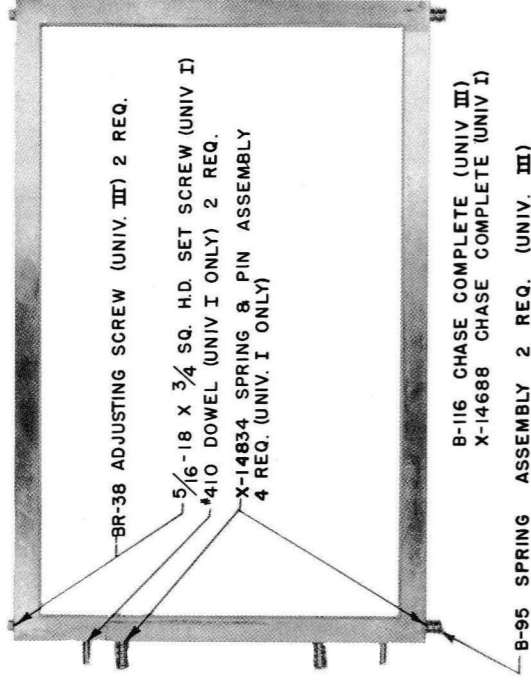

BR-38 ADJUSTING SCREW (UNIV. III) 2 REQ.  
 5/16-18 X 3/4 SQ. H.D. SET SCREW (UNIV. I)  
 #410 DOWEL (UNIV. I ONLY) 2 REQ.  
 X-14834 SPRING & PIN ASSEMBLY  
 4 REQ. (UNIV. I ONLY)

B-95 SPRING ASSEMBLY 2 REQ. (UNIV. III)  
 B-116 CHASE COMPLETE (UNIV. III)  
 X-14688 CHASE COMPLETE (UNIV. I)

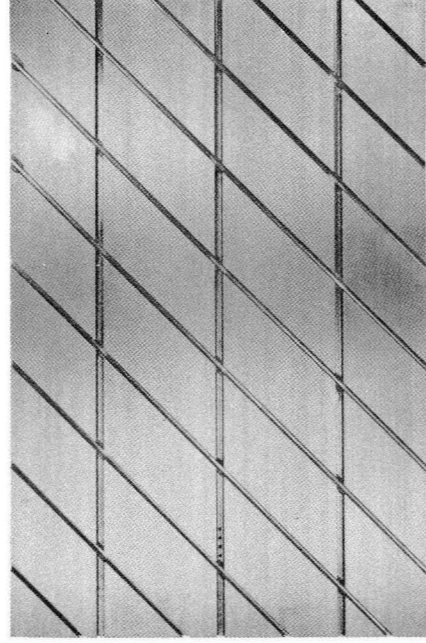

BM-8 MALLET  
 BN-31 MALLET COMPLETE

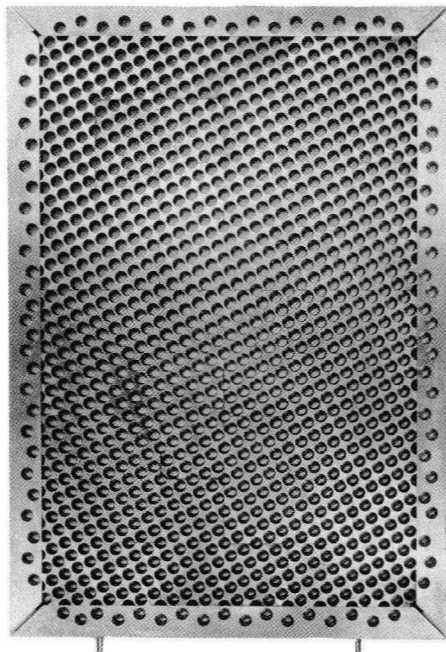

X-14843 STERLING BLOCK BASE WITH TWO WRENCHES  
 SHOWN BELOW (UNIV. I) X-5766 FOR UNIV. III

BS-107 PLATE LIFTER  
 BS-270 INSERT  
 BA-15 WRENCH  
 BR-81 PIN  
 B-104 HEAD BLOCK  
 BR-152 PIN FOR 16 GA. PLATES (UNIV. I) - X-14685 (UNIV. III) - X-18001  
 BS-50 SIDE HOOK  
 BR-353 SET SCREW USED IN ALL ABOVE BLOCKS EXCEPT BS-50 USES BR-220  
 X-2510 HOLD DOWN BLOCK

F-736 3/8 ALLEN WRENCH  
 X-5763 KEY  
 X-5764 KEY BIT  
 X-5765 HOOK FOR ELECTROS  
 X-6978 HOOK FOR ORIGINALS  
 X-16169 SPECIAL 5/8 OPEN END WRENCH

X-10275 SHOULDER SCREW  
 X-11405 BAR (UN. I)  
 X-11646 BAR (UN. III)

X-11411 RUBBER  
 X-11407 PLATE

10-24 X 1/8 HD. SCREW CADMIUM PLATED  
 X-14847 BLOCK  
 NRS-23 SPRING  
 X-11406 SHAFT (UNIV. I)  
 X-11643 SHAFT (UNIV. III)  
 NR-255 CAM RIDER  
 1/4-20 X 1/4 SOCKET SET SCREW  
 NR-253 CAM  
 X-11642 HANDLE  
 X-11409 HANDLE END  
 X-15279 WARNING TAG (UNIV. I ONLY)  
 X-11403 LOCKUP BAR (UNIV. I)  
 X-11644 LOCKUP BAR (UNIV. III)

X-14022 TOGGLE SWITCH (SINGLE PHASE & D.C.) (UNIV. I ONLY)  
 X-14027 TOGGLE SWITCH (3 PHASE) (UNIV. I ONLY)

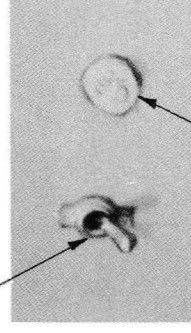

X-9481 PILOT LIGHT  
 X-9557 NEON LAMP  
 X-10982 RESISTOR ASSEM. (FOR 220 V)  
 X-10981 RESISTOR ASSEM (FOR 440V.)

X-14848 LOCKUP BAR ASSEMBLY COMPLETE (UN. I)  
 X-11645 LOCKUP BAR ASSEMBLY COMPLETE (UN. III)

VANDERCOOK UNIVERSAL I & III TEST PRESSES

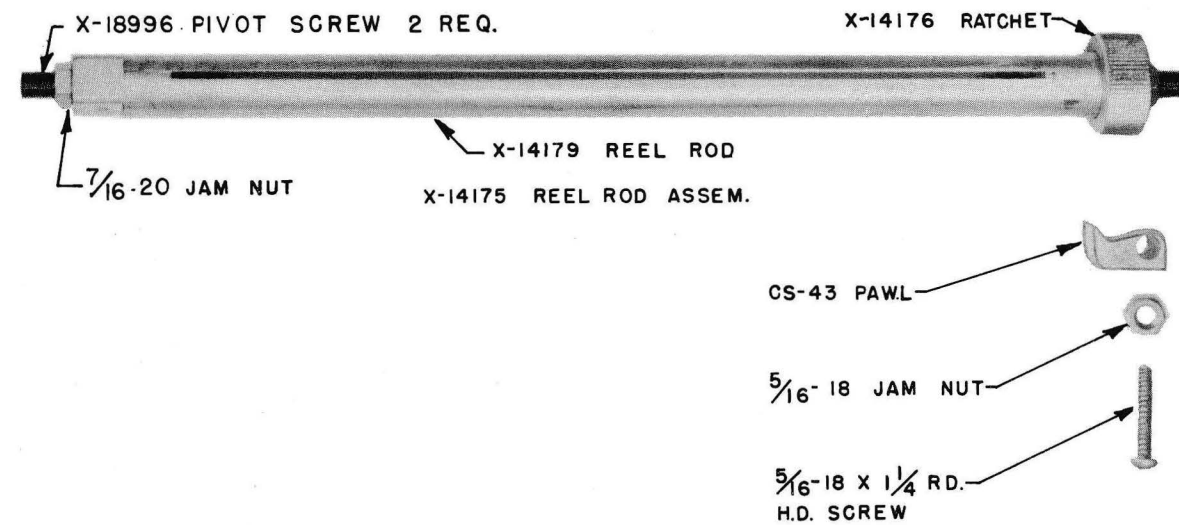
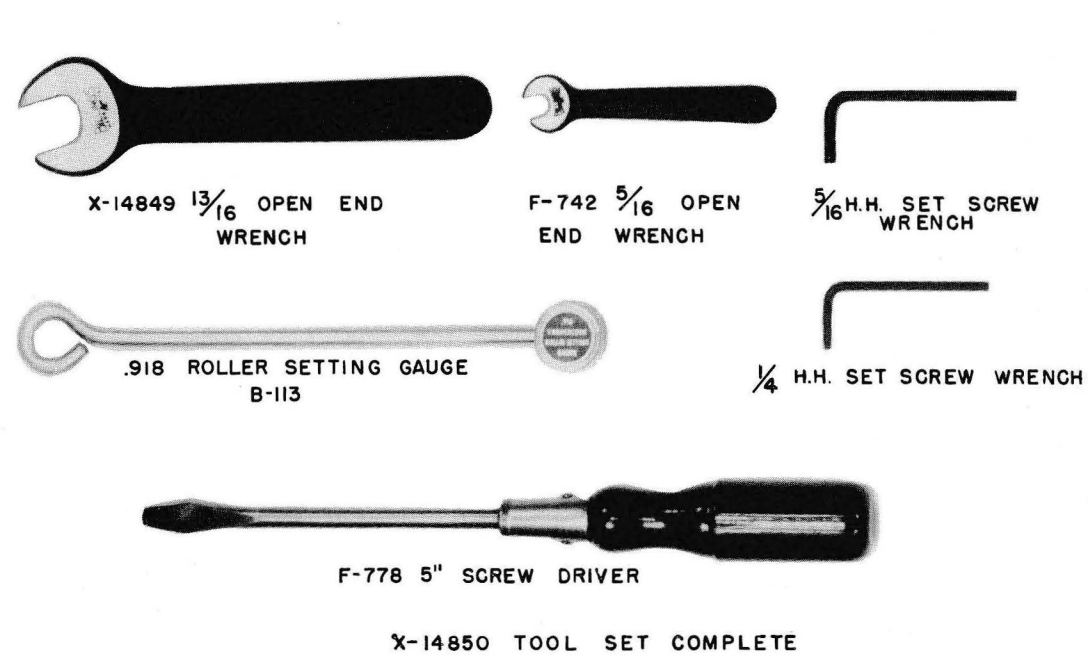
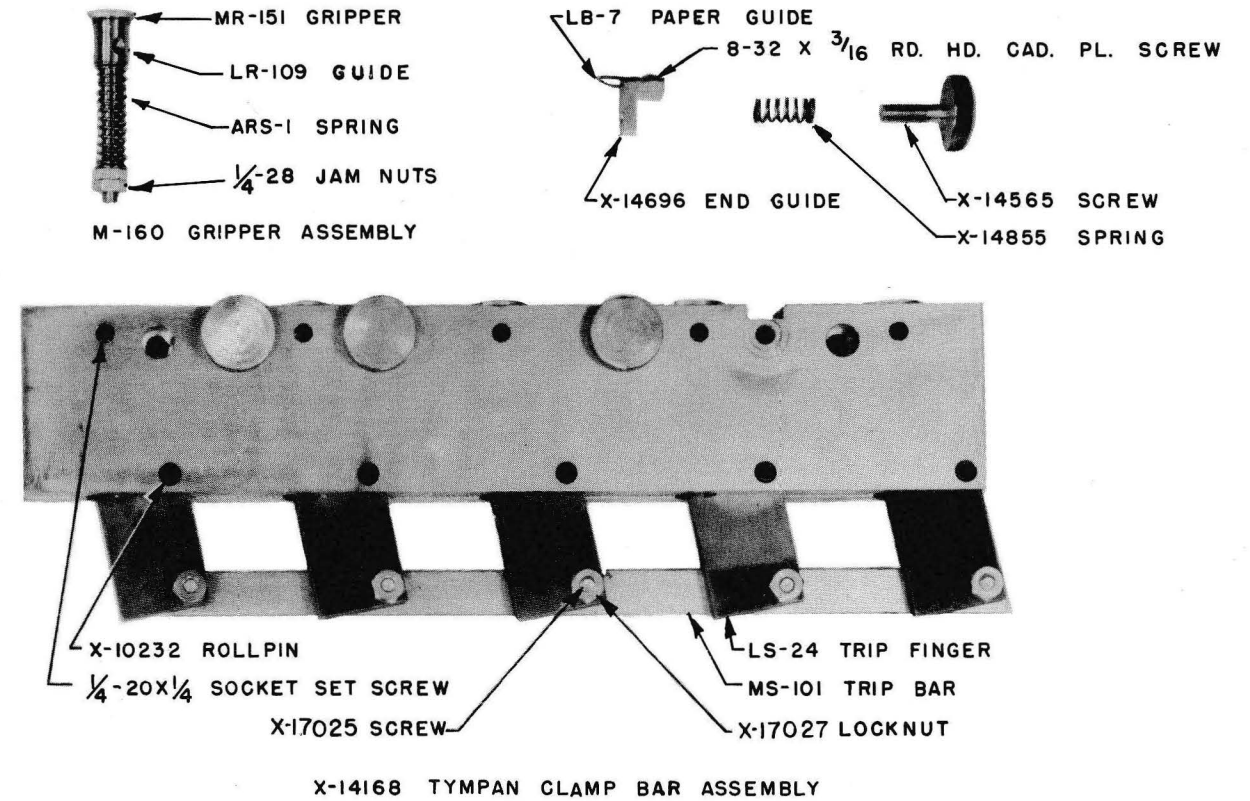
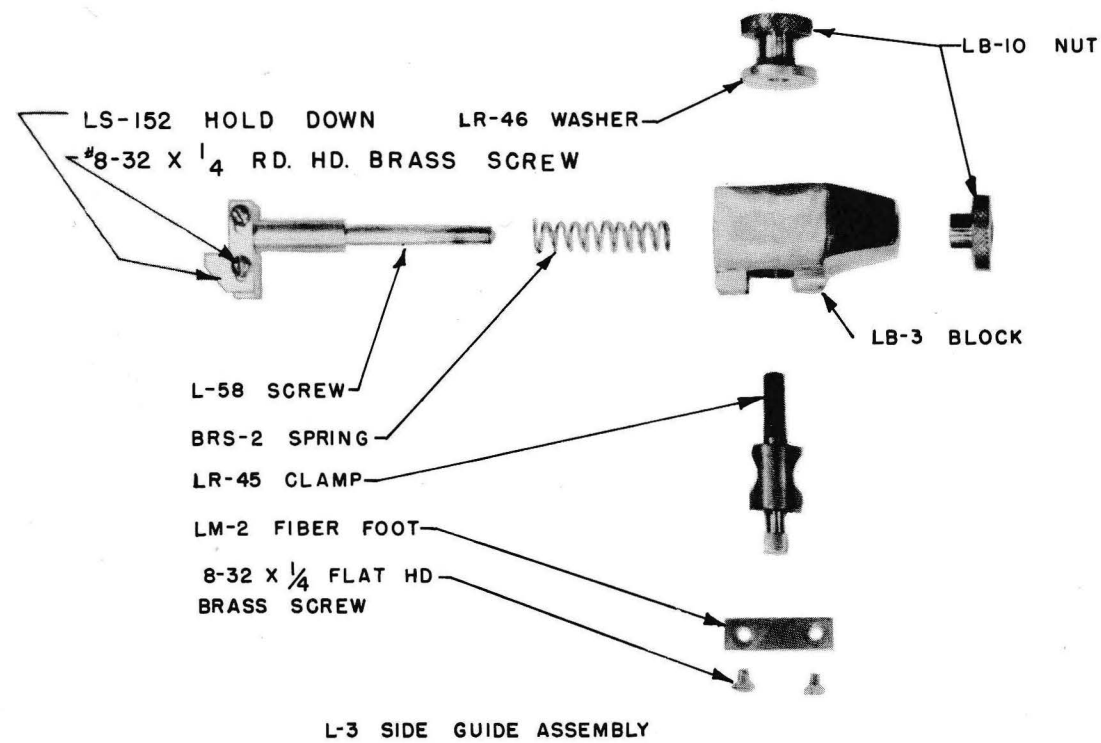

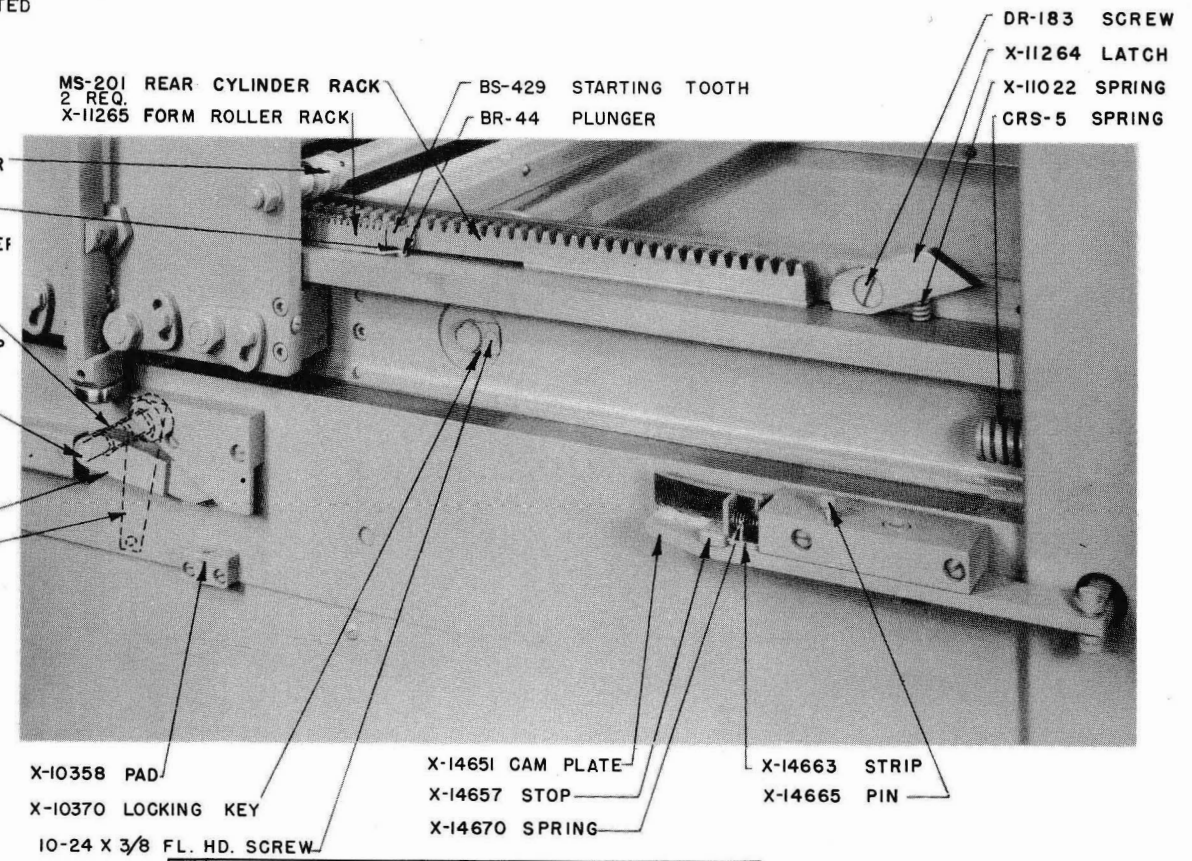
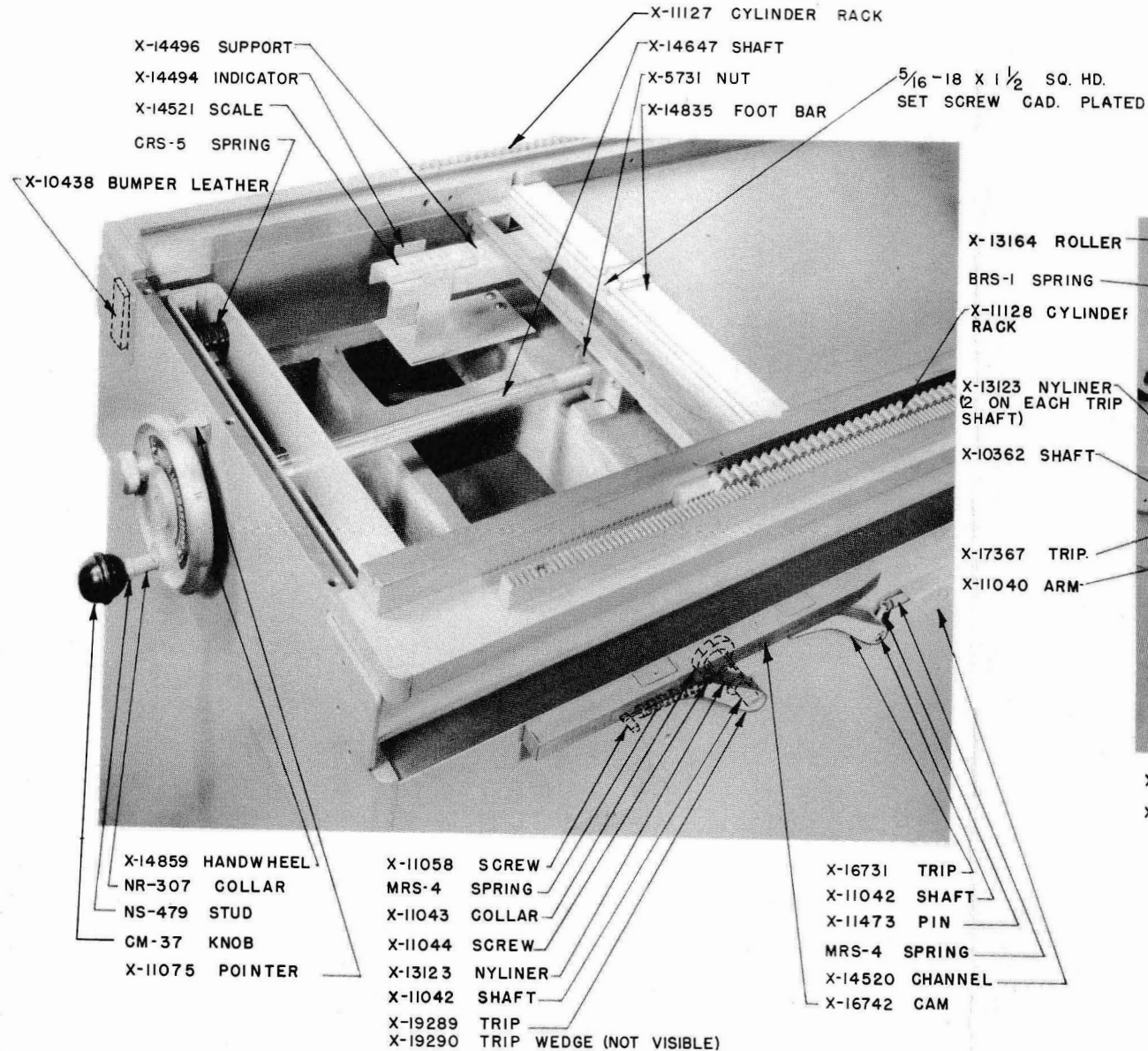
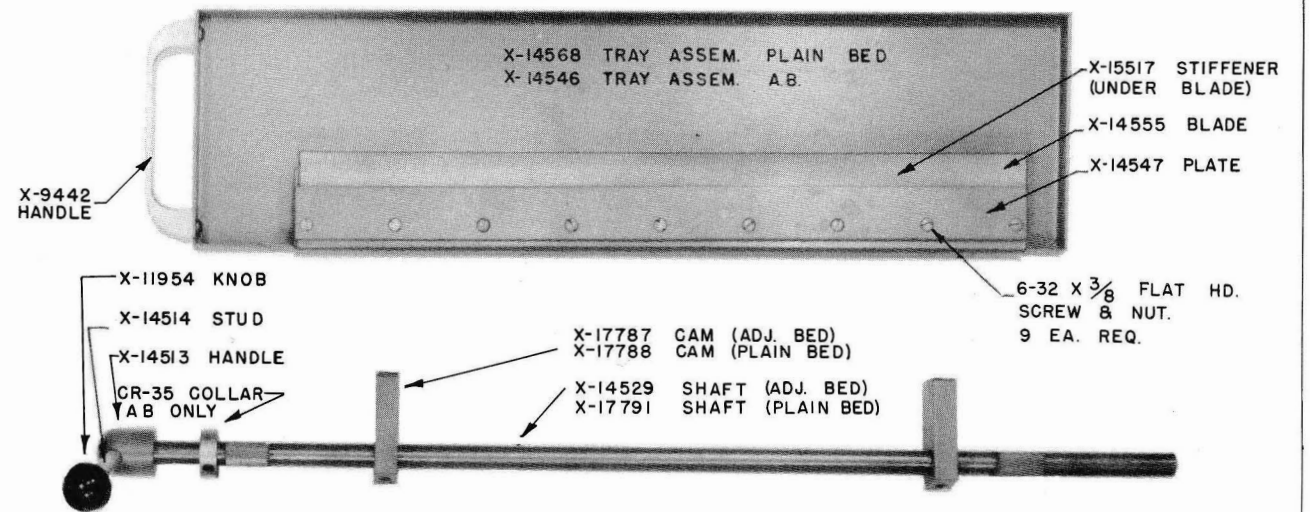
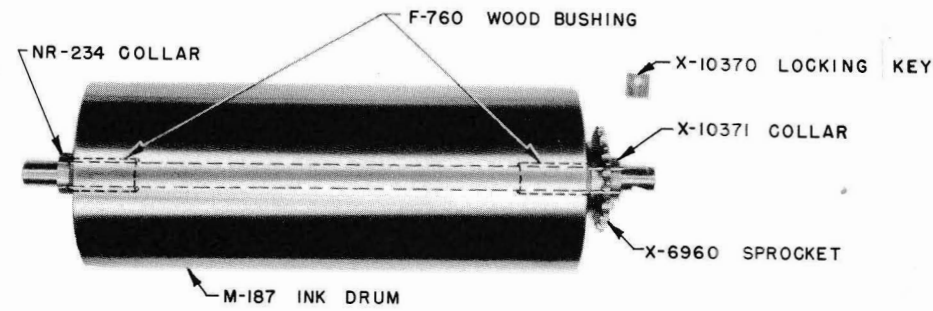

- X-14859 HANDWHEEL
- NR-307 COLLAR
- NS-479 STUD
- CM-37 KNOB
- X-11075 POINTER
- X-11058 SCREW
- MRS-4 SPRING
- X-11043 COLLAR
- X-11044 SCREW
- X-13123 NYLINER
- X-11042 SHAFT
- X-19289 TRIP
- X-19290 TRIP WEDGE (NOT VISIBLE)
- X-16731 TRIP
- X-11042 SHAFT
- X-11473 PIN
- MRS-4 SPRING
- X-14520 CHANNEL
- X-16742 CAM

**LUBRICATION**  
 SAE #20 MOTOR OIL IS RECOMMENDED FOR ALL MOVING PARTS. OIL WEEKLY. A LIGHT FILM OF OIL SHOULD BE KEPT ON RACKS & BEARING RAILS AT ALL TIMES.  
 IN CASE OF REPLACEMENT OF TAPER BEDS LUBRICATE WITH MOLYKOTE TYPE Z.

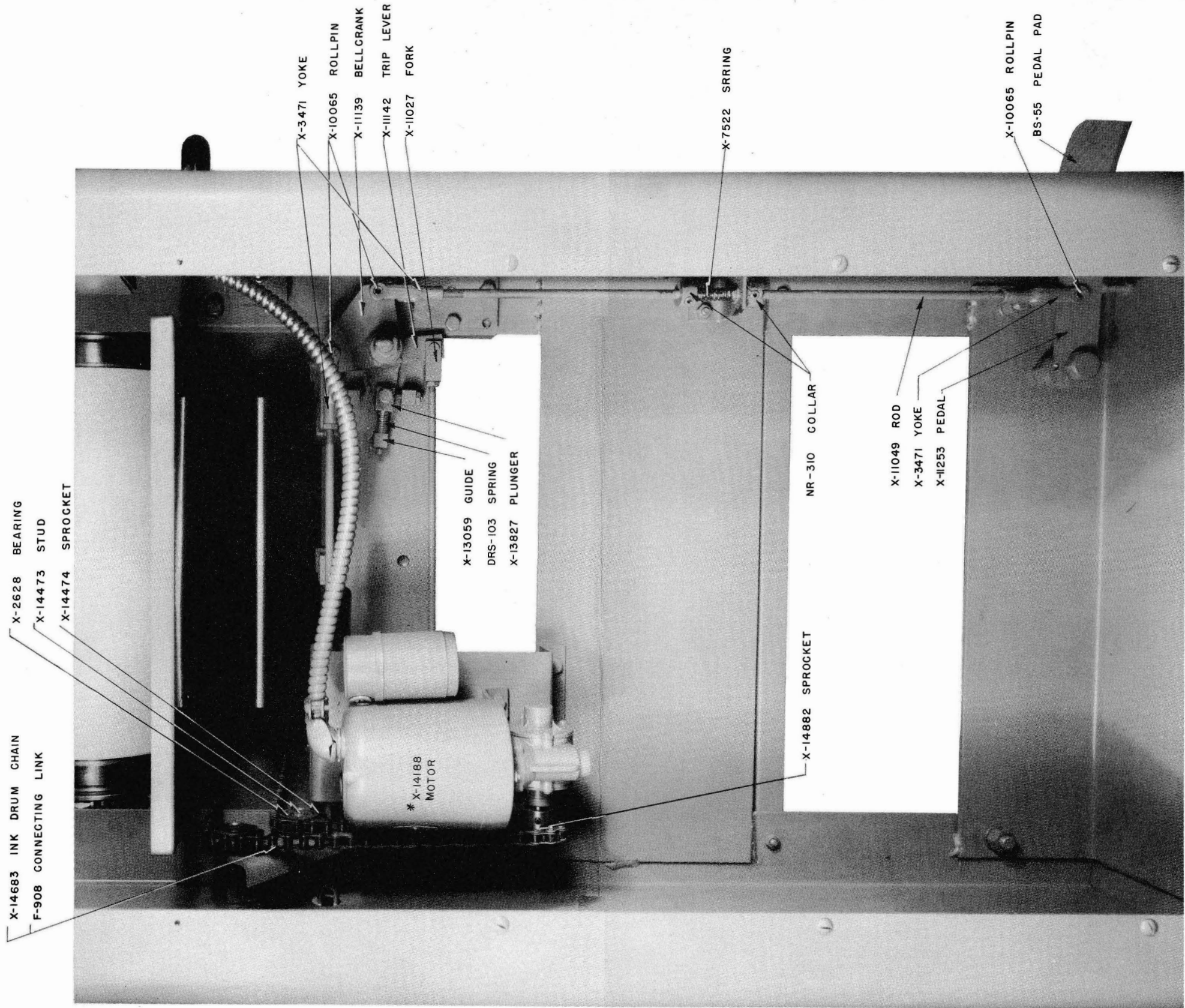

X-14683 INK DRUM CHAIN  
 F-908 CONNECTING LINK  
 X-2628 BEARING  
 X-14473 STUD  
 X-14474 SPROCKET

X-3471 YOKE  
 X-10065 ROLLPIN  
 X-11139 BELLGRANK  
 X-11142 TRIP LEVER  
 X-11027 FORK

X-13059 GUIDE  
 DRS-103 SPRING  
 X-13827 PLUNGER

X-7522 SRRING

X-14882 SPROCKET

NR-310 COLLAR

X-11049 ROD  
 X-3471 YOKE  
 X-11253 PEDAL

X-10065 ROLLPIN  
 BS-55 PEDAL PAD

**LUBRICATION**  
 S.A.E. #20 MOTOR OIL IS RECOMMENDED FOR ALL MOVING PARTS, OIL WEEKLY.  
 ALL BALL BEARINGS ARE PACKED IN GREASE AND REQUIRE NO FURTHER ATTENTION.  
 FOLLOW MOTOR MANUFACTURERS INSTRUCTIONS FOR MOTOR.

\* WHEN ORDERING MOTOR SPECIFY VOLTAGE, PHASE, & CYCLE.

VANDERCOOK UNIVERSAL I TEST PRESS

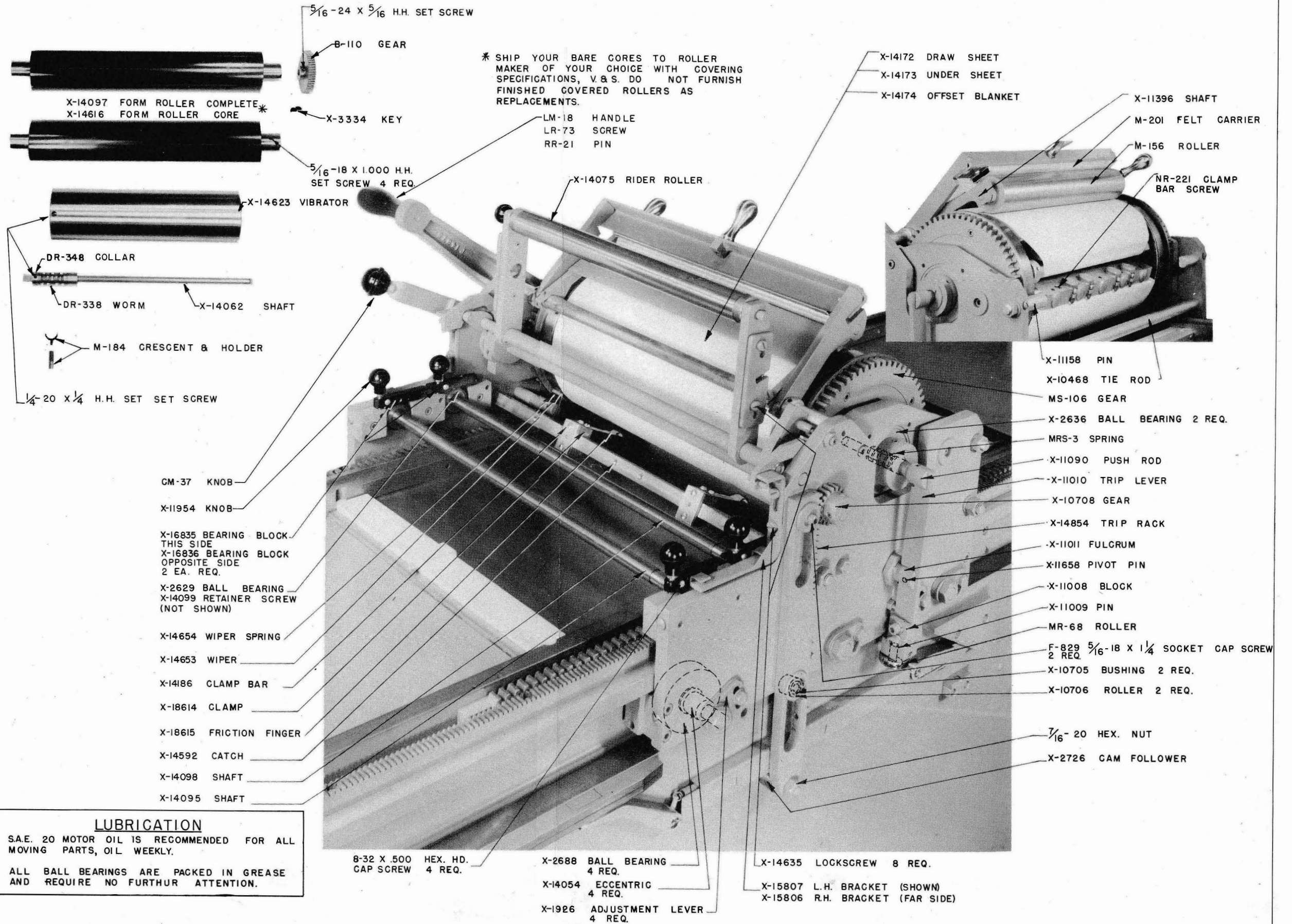

**LUBRICATION**

SAE. 20 MOTOR OIL IS RECOMMENDED FOR ALL MOVING PARTS, OIL WEEKLY.

ALL BALL BEARINGS ARE PACKED IN GREASE AND REQUIRE NO FURTHER ATTENTION.

## VANDERCOOK UNIVERSAL I TEST PRESS

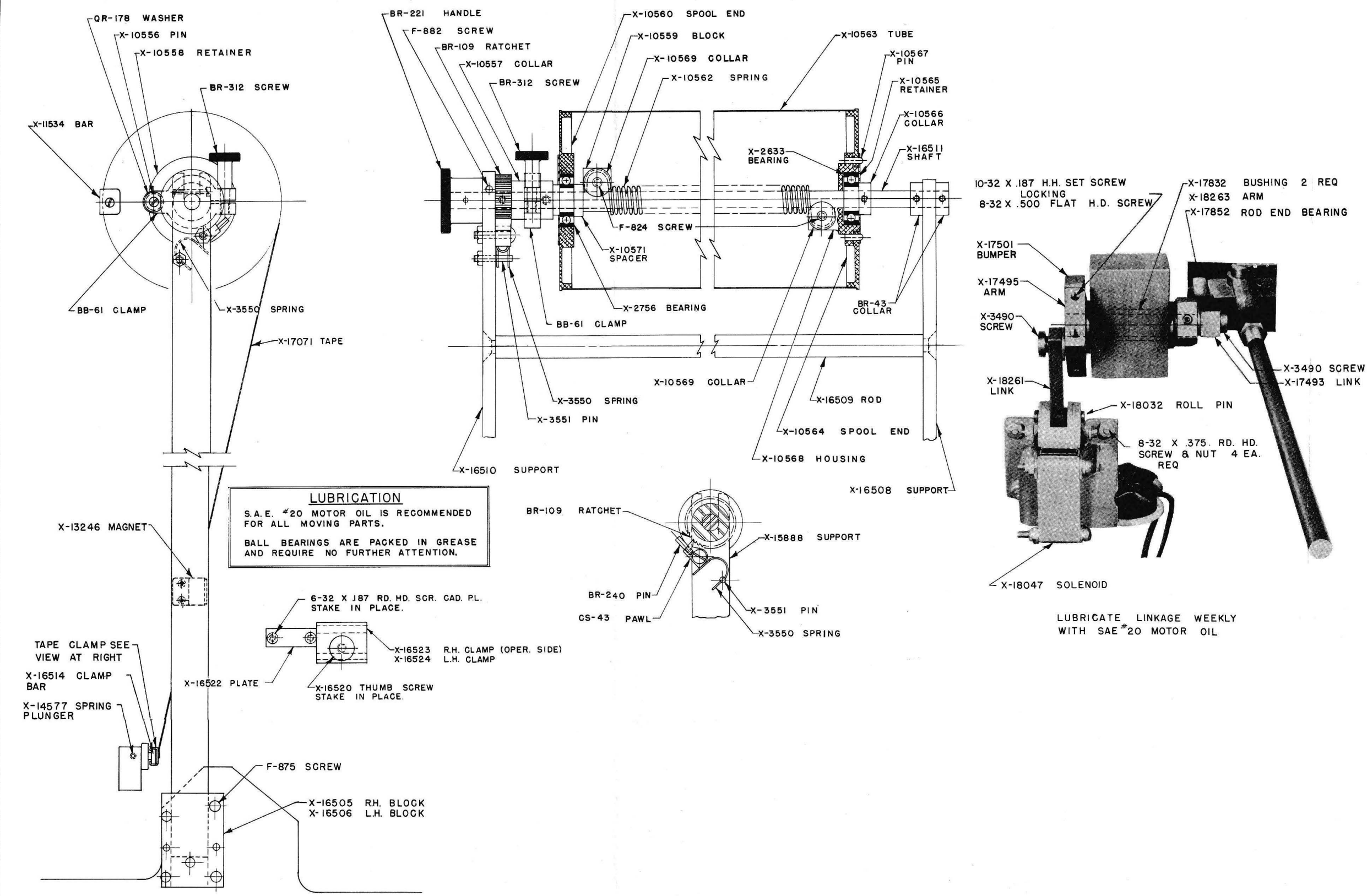

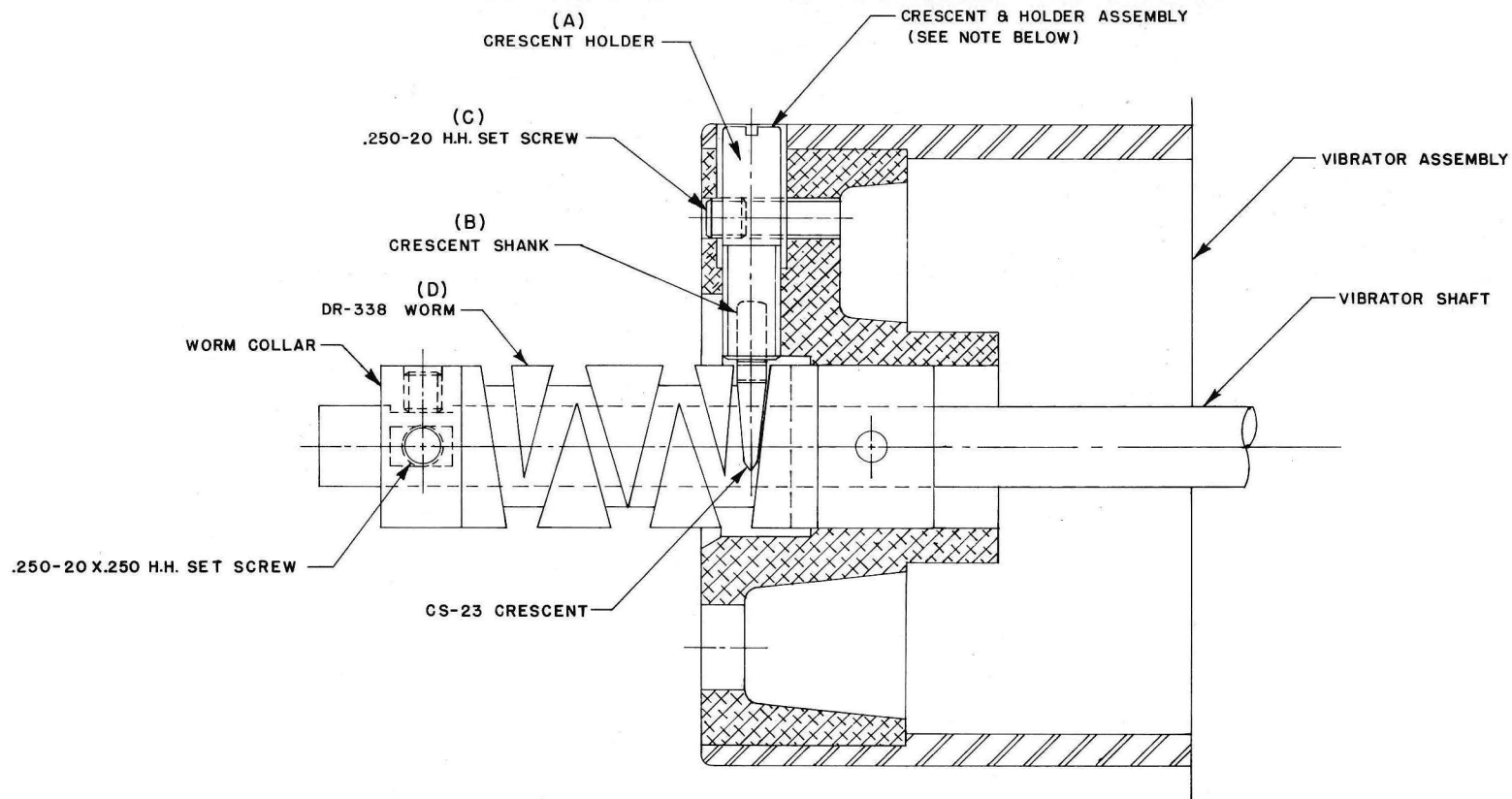

PARTIAL SECTION VIEW OF INK DRUM VIBRATOR ASSEMBLY

- ① ADJUST CRESCENT HOLDER-(A) UNTIL IT TOUCHES END OF CRESCENT SHANK-(B). THEN BACK OFF  $\frac{3}{4}$  OF A TURN AND LOCK HOLDER WITH .250-20 H.H. SET SCREW-(C). THIS SETTING MUST ALLOW WORM-(D) TO ROTATE FREE OF ANY DRAG, TRAVELING FULL LENGTH BOTH DIRECTIONS.
- ② COAT VIBRATOR WORM WITH GRAPHITE GREASE OR VASELINE.

NOTE— CRESCENT AND HOLDER ASSEMBLY AS SHOWN IS PART NO. M-184. THE ABOVE INSTRUCTIONS APPLY ALSO TO X-2031 CRESCENT AND HOLDER ASSEMBLY (NOT SHOWN).

CRESCENT OR WORM REPLACEMENT INSTRUCTIONS

37





