

PINO TROGU – SAN FRANCISCO STATE UNIVERSITY, USA

ARISTOTLE'S LANTERN

TWO BIOINSPIRED DESIGNS

BASED ON GIORGIO SCARPA'S MODEL OF A SEA URCHIN:
A BIOPSY HARVESTER AND A GROUND SAMPLER

SAN FRANCISCO

WEDNESDAY, DECEMBER 9, 2015

FINE ARTS BLDG, ROOM 115

[go to last slide](#)

Giorgio Scarpa - Bionic Models ...

online.sfsu.edu/trogu/scarpa/

Giorgio Scarpa

Italian designer, bionics researcher, teacher, and artist.

Profile and videos by **Pino Trogu**, San Francisco State University [trogu at sfsu dot edu]

The short videos below refer to the topics of Scarpa's two books. The first is a bionic study of the mouth apparatus of the sea urchin, also known as Aristotle's Lantern, after the first detailed study of it by the Greek philosopher. The PDF of the book (unpublished draft English translation) is at right. The second shows one of the many modular chains described in the rotational geometry book, which focuses on rotational movement as a basic form generating process. Scarpa dissects the five Platonic solids and other solids into chains of hinged triangular pyramids that fold back into their enclosure cells. Both books were published as part of a now out-of-print series called "Design Notebooks", edited by the late Italian designer Bruno Munari. The covers of the books in that series are shown below. The other videos show more topological and bionic studies by Scarpa, including DNA models and studies of muscle structure.

This page was last updated on Tuesday, May 27, 2014.

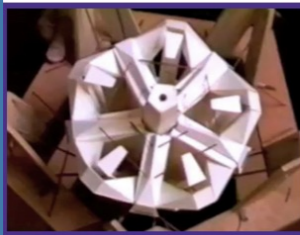

[Bionic Model of Aristotle's Lantern](#)
Video length: 1'-12". Video: Pino Trogu, 1994.

[Bionic Model of Aristotle's Lantern](#)
Video length: 1'-12".

Citations:
[Bioinspired Spring-Loaded Biopsy Harvester — Experimental Prototype Design and Feasibility Tests](#)
Filip Jelínek, Gerwin Smit and Paul Breedveld
Journal of Medical Devices 8(1), March 2014.



Click [here](#) to download PDF of pages 3-20 and 60-74 only. File size: 13MB.

Click image to download PDF of complete Bionic Models book. Unpublished English translation of Italian Edition: Modelli di Bionica, 1985. Translated by Pino Trogu. 122 pages. File size: 38MB.

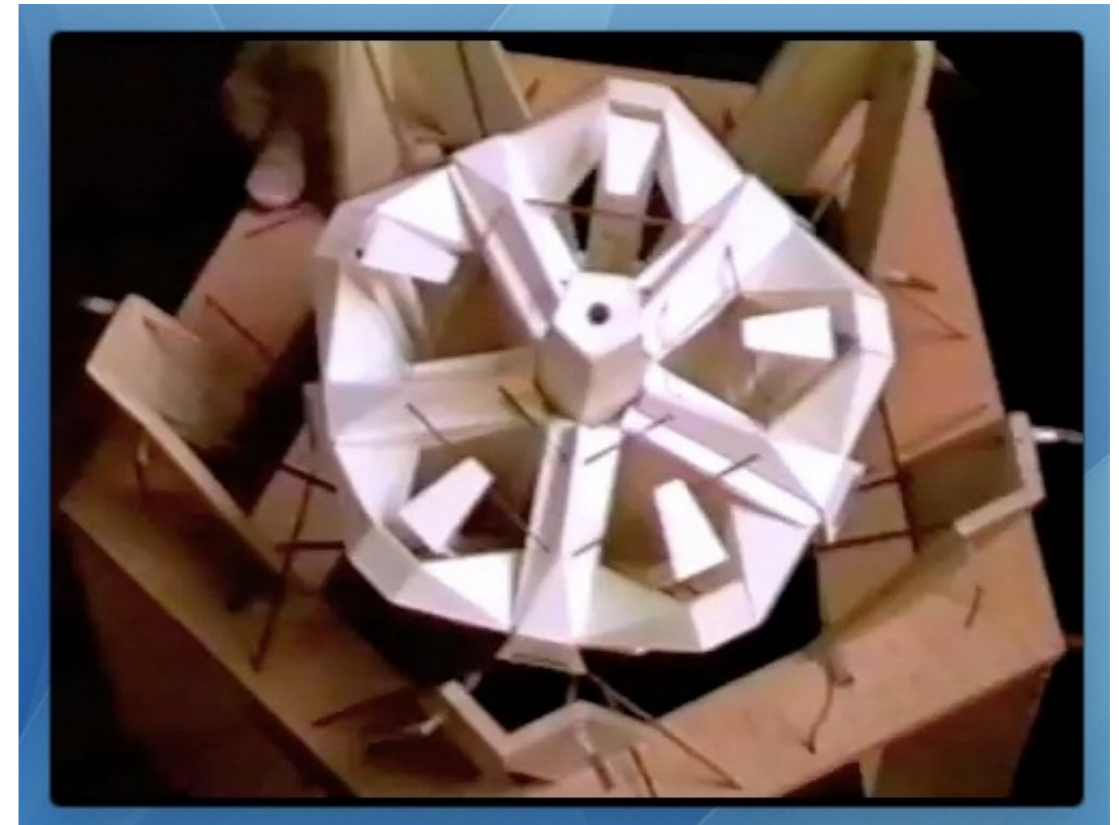

<http://online.sfsu.edu/trogu/scarpa/>



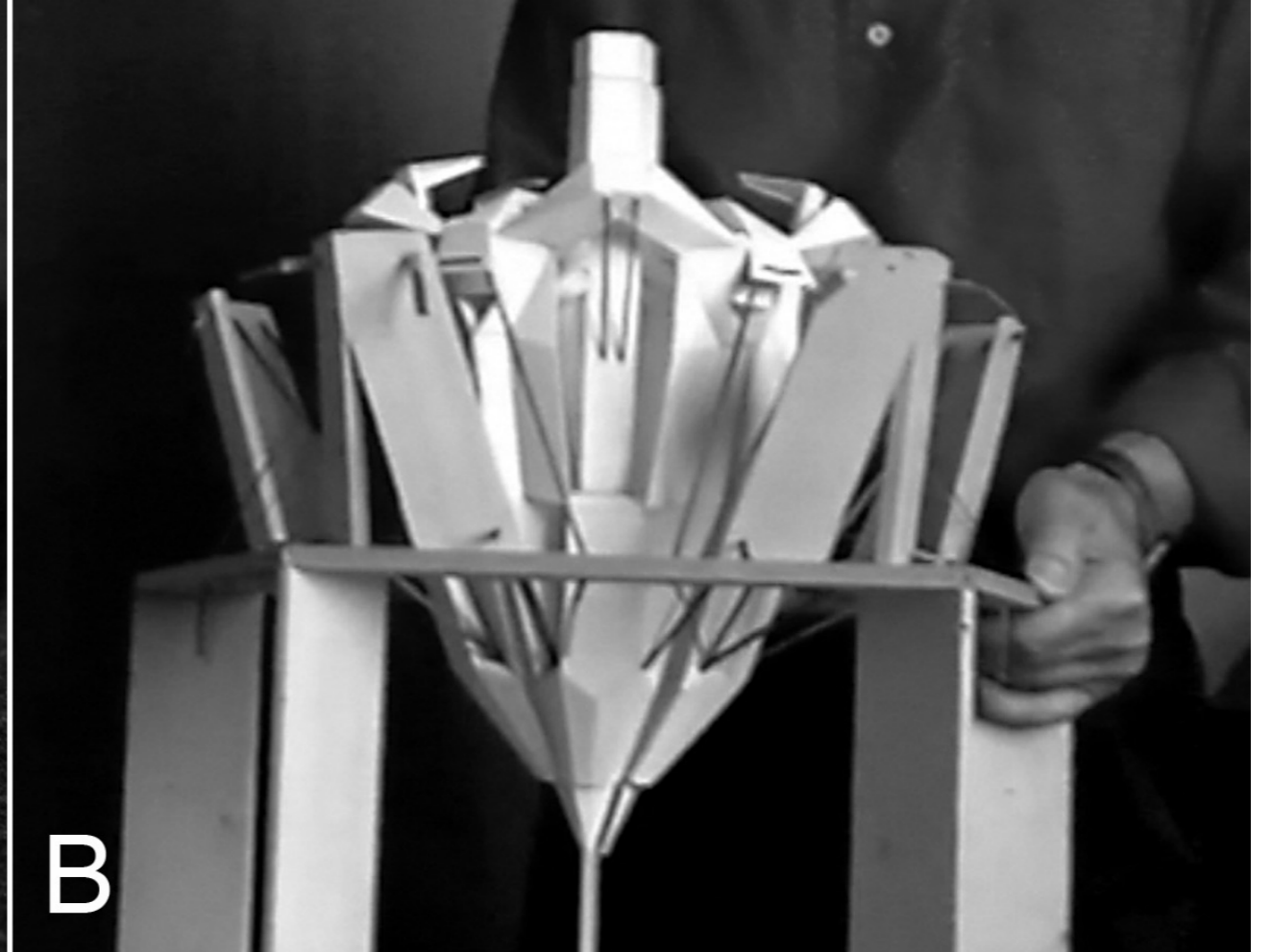

Photo: Giorgio Cireddu



jaw

tooth

rotula

compass

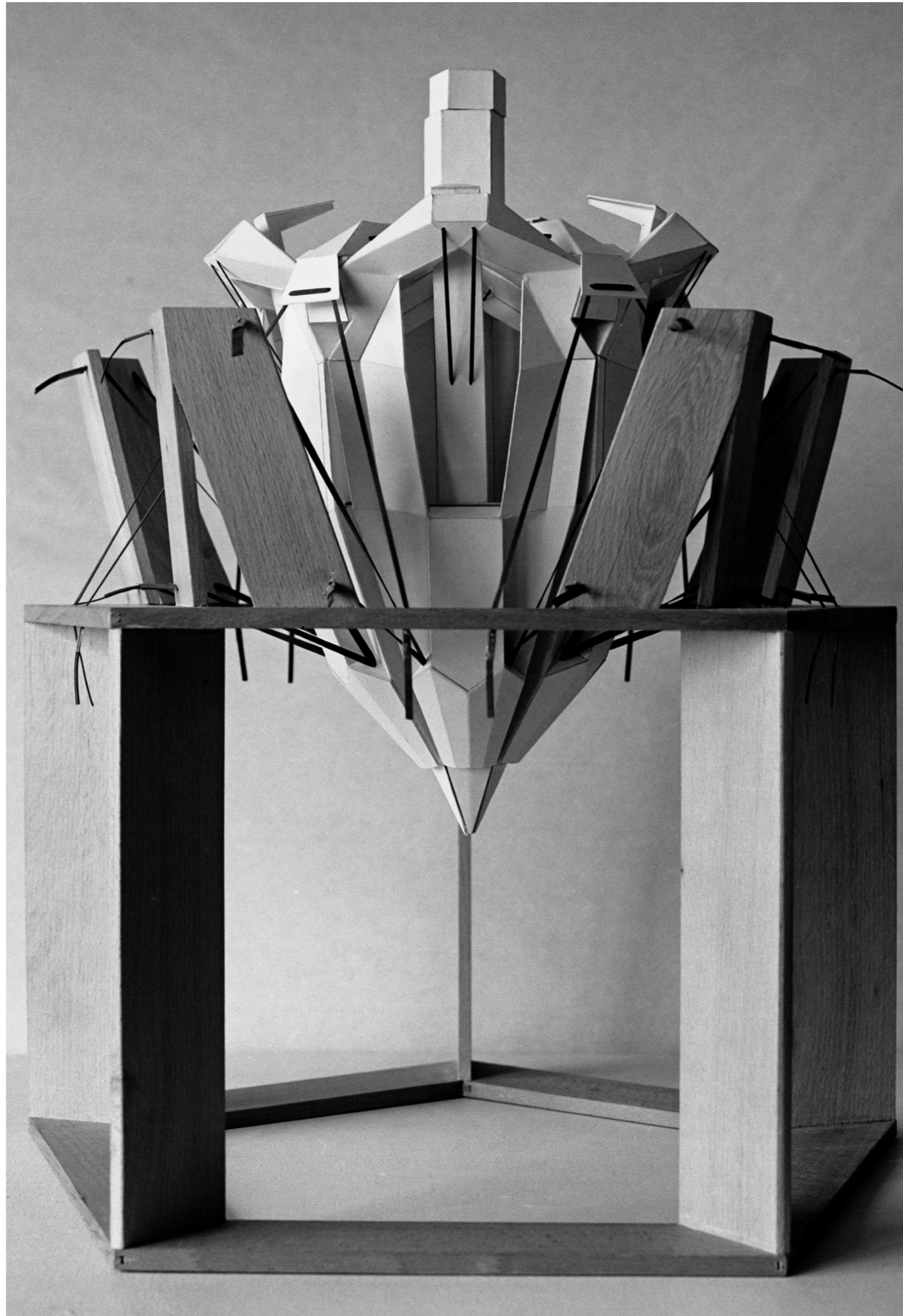
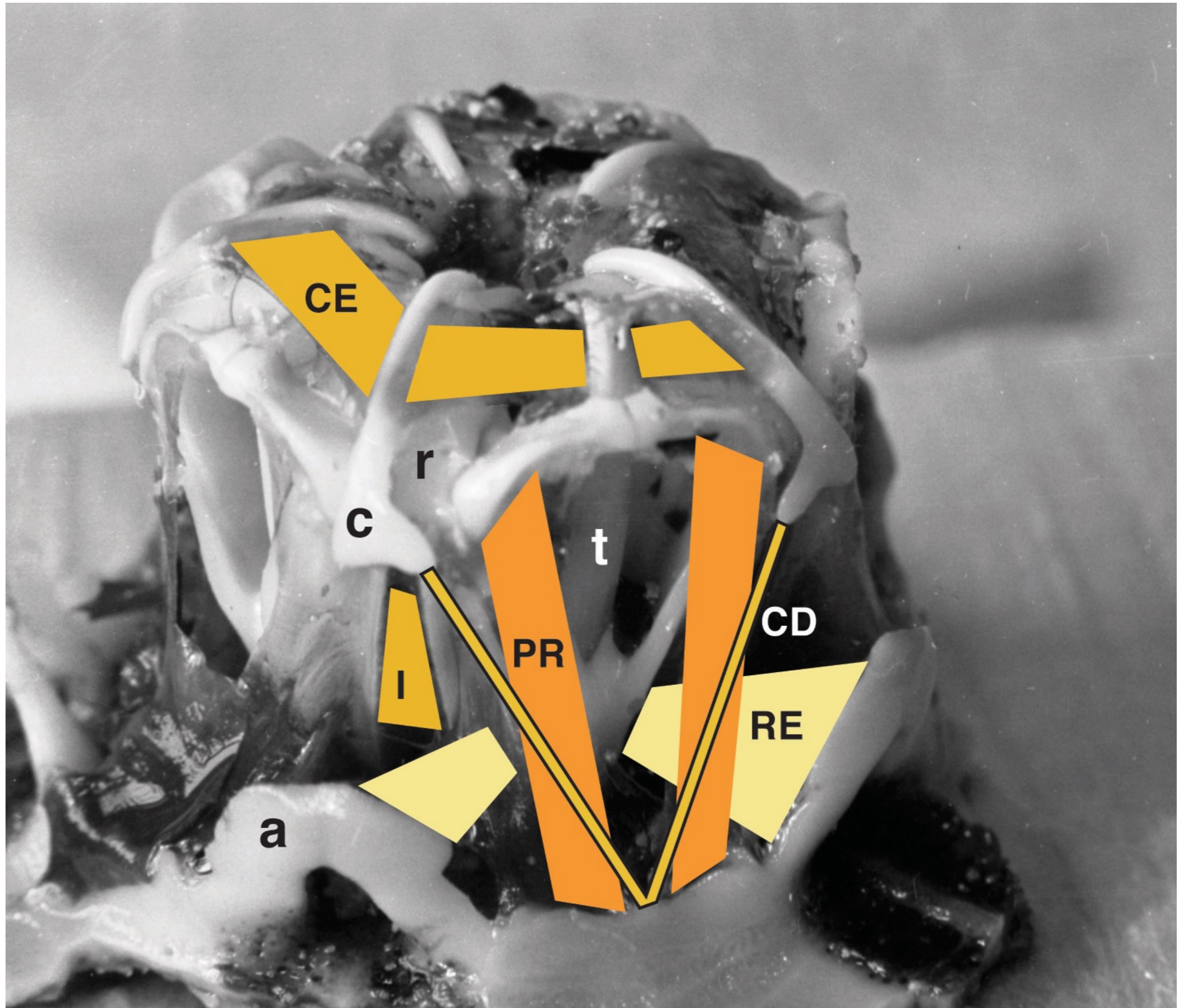
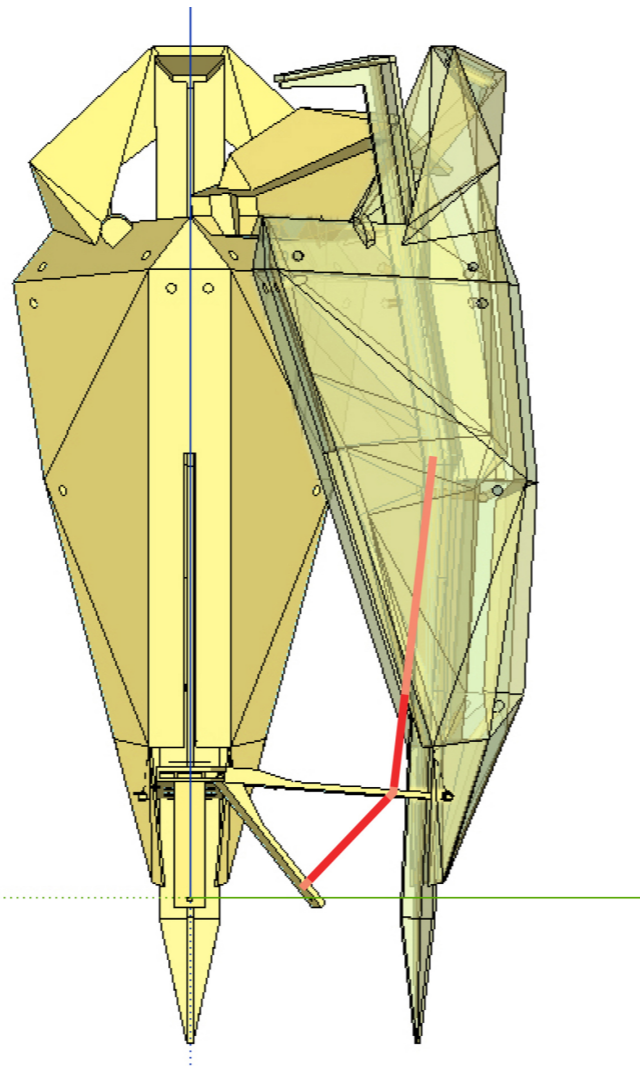

Photo: Giorgio Cireddu





Original paper model,
detail. C. 1970.



SketchUp model,
detail. 2014.

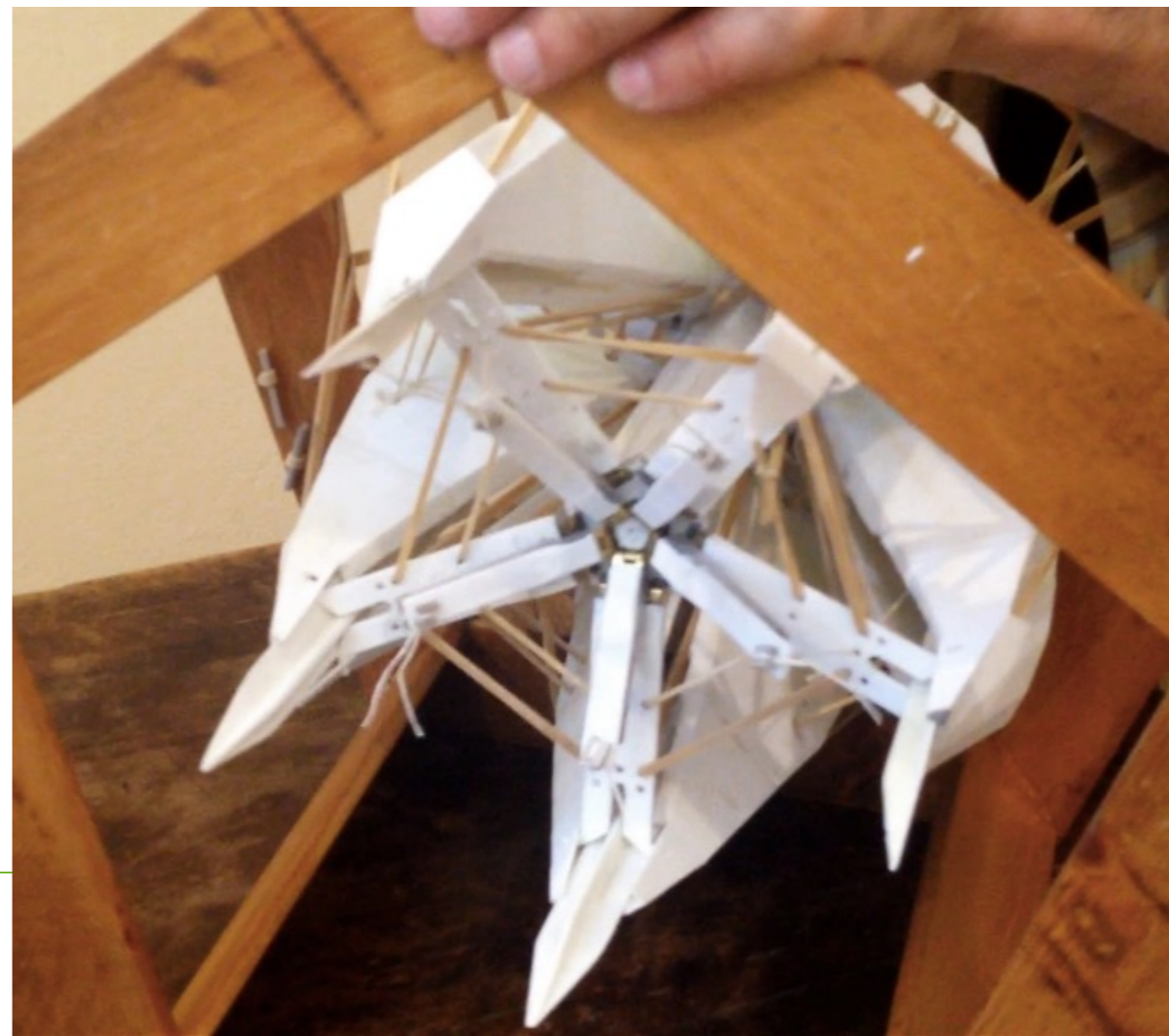

3D-printed replica, 2014

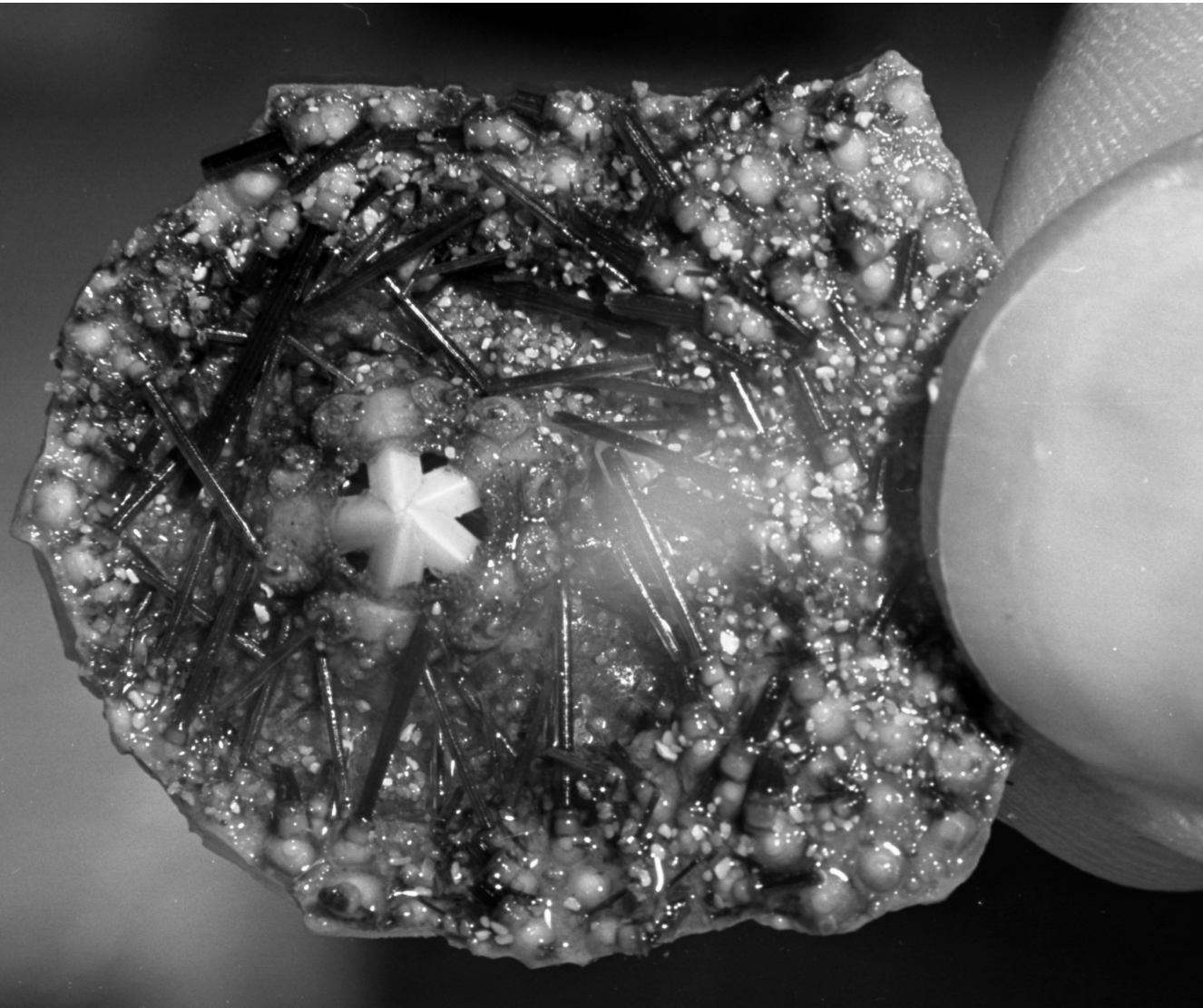

Teeth are visible in middle of perignathic membrane.

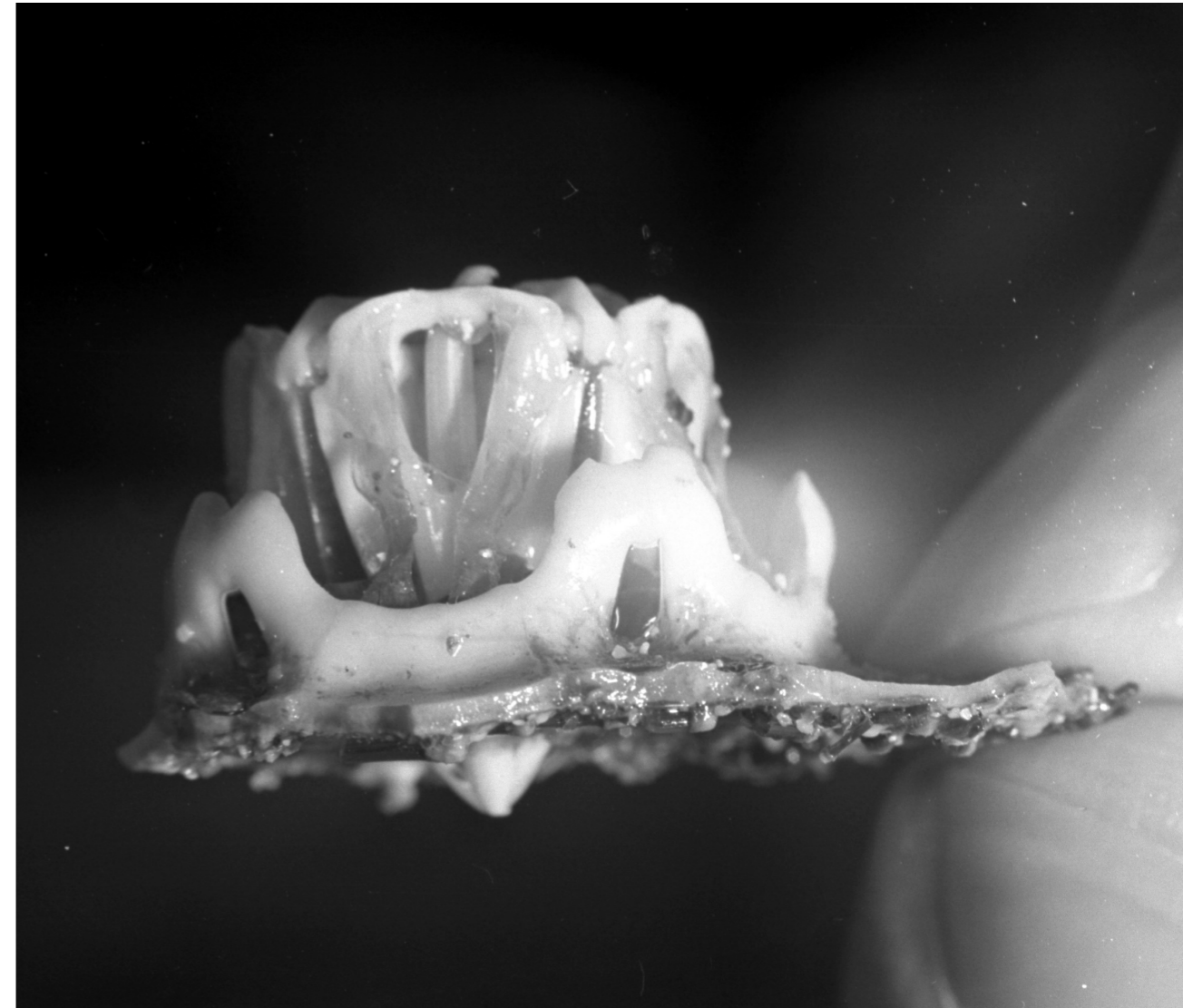

Side view of lantern and auricles.

Photo: Giorgio Cireddu

Living Machines 2014

30 July-1 Aug.

Museo Nazionale
della Scienza e
della Tecnologia
Leonardo da Vinci,
Milano

The 3rd Conference on Biomimetic and Biohybrid Systems

on!

Conference

- About
- Plenary talks
- Programme
- Submission

Committees

Venue

Registration

- Scholarships

Accommodation

Workshops

LM Editions

Contact

LM2015 photos



Supported by



Welcome to Living Machines 2014

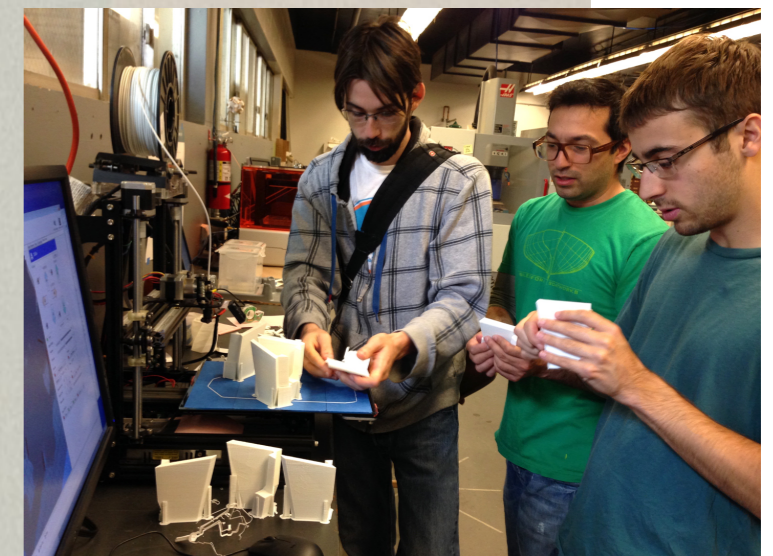
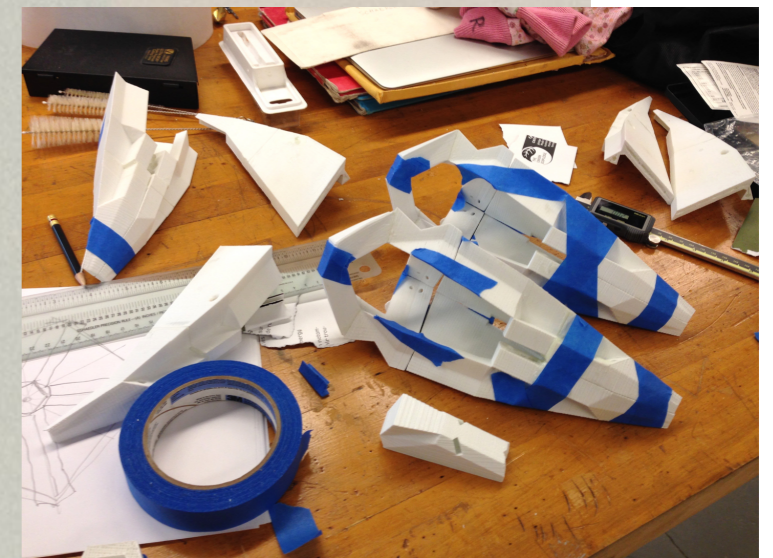

Silvan Linn
Richard Ortiz,
Francesco Trogu



Living Machines 2014, Milano



Europe Edition
September 8-9 2015, Austria
Vienna / Wiener Neustadt

Design of Medical Devices conference



www.designofmedicaldevices.eu



Air France SFO → Paris

Filip Jelínek

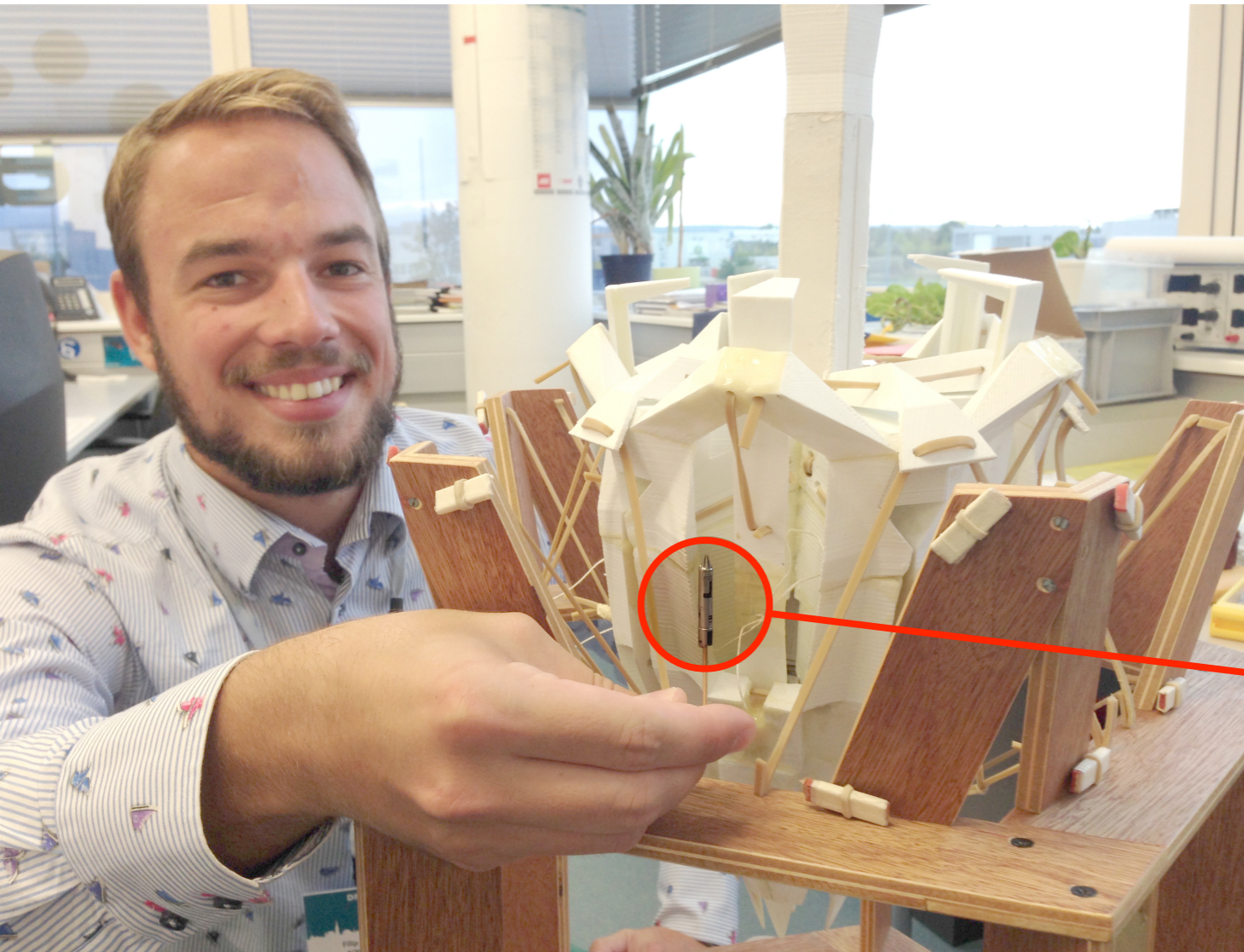

Giorgio Scarpa

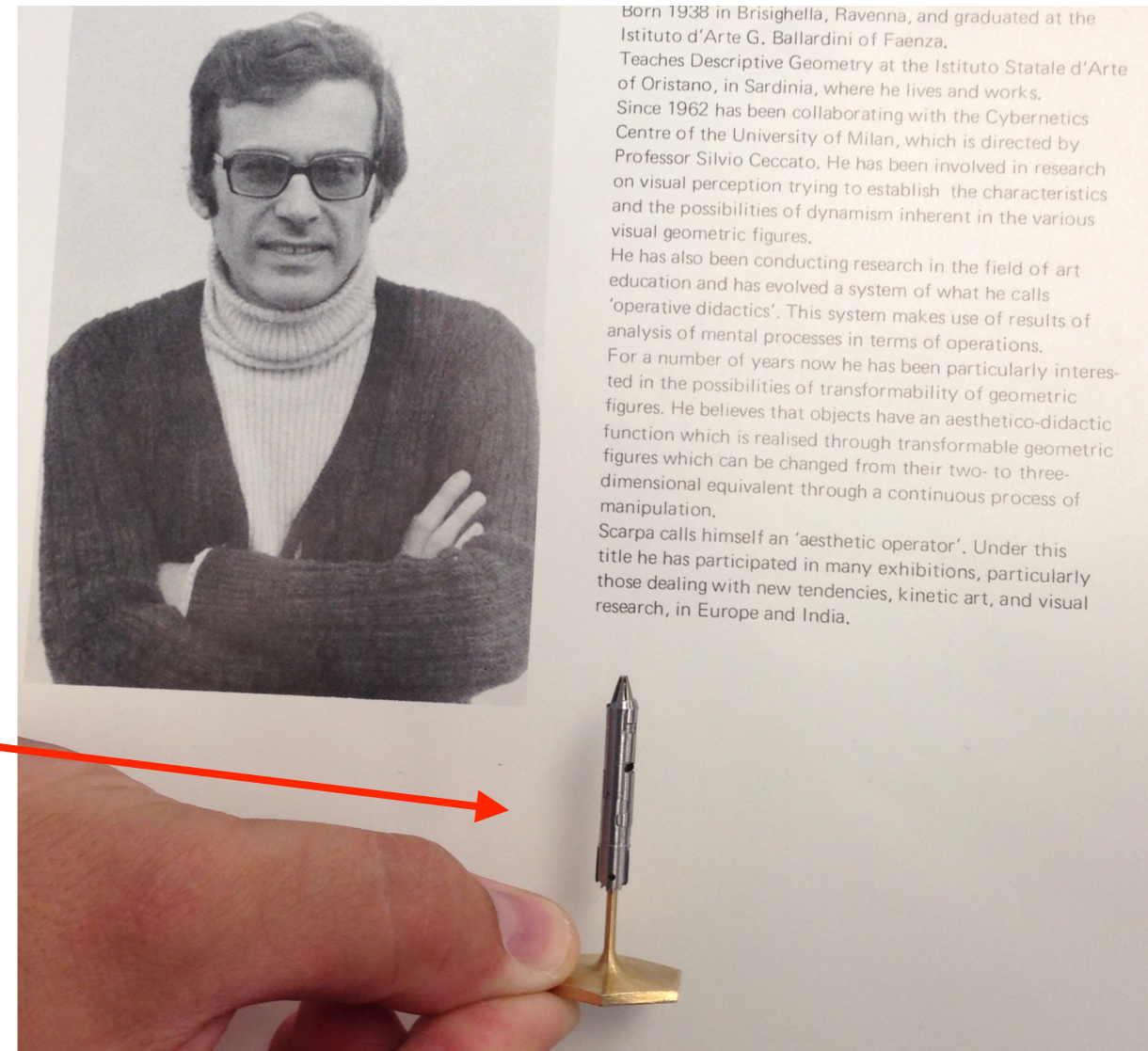

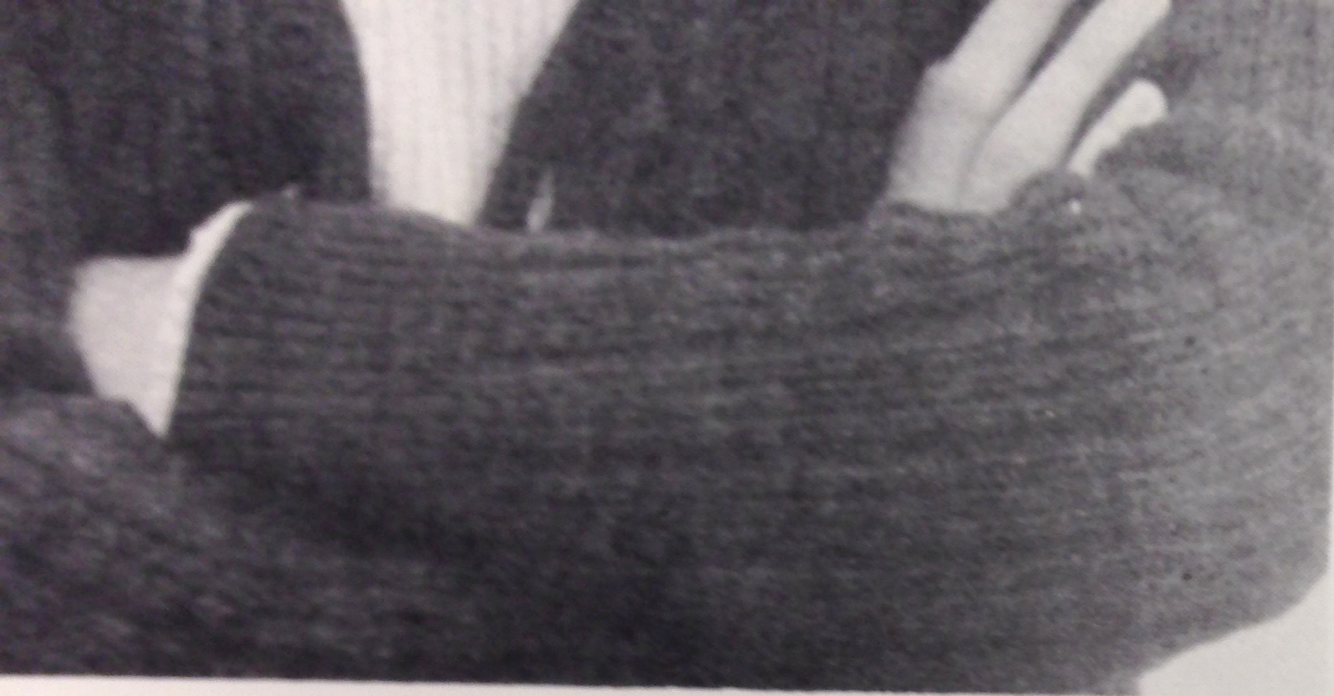

manipulation.
Scarpa calls himself an 'aesthetic operat
title he has participated in many exhibit
those dealing with new tendencies, kine
research, in E

(Jelínek, Smit, Breedveld, UT Delft, 2014)

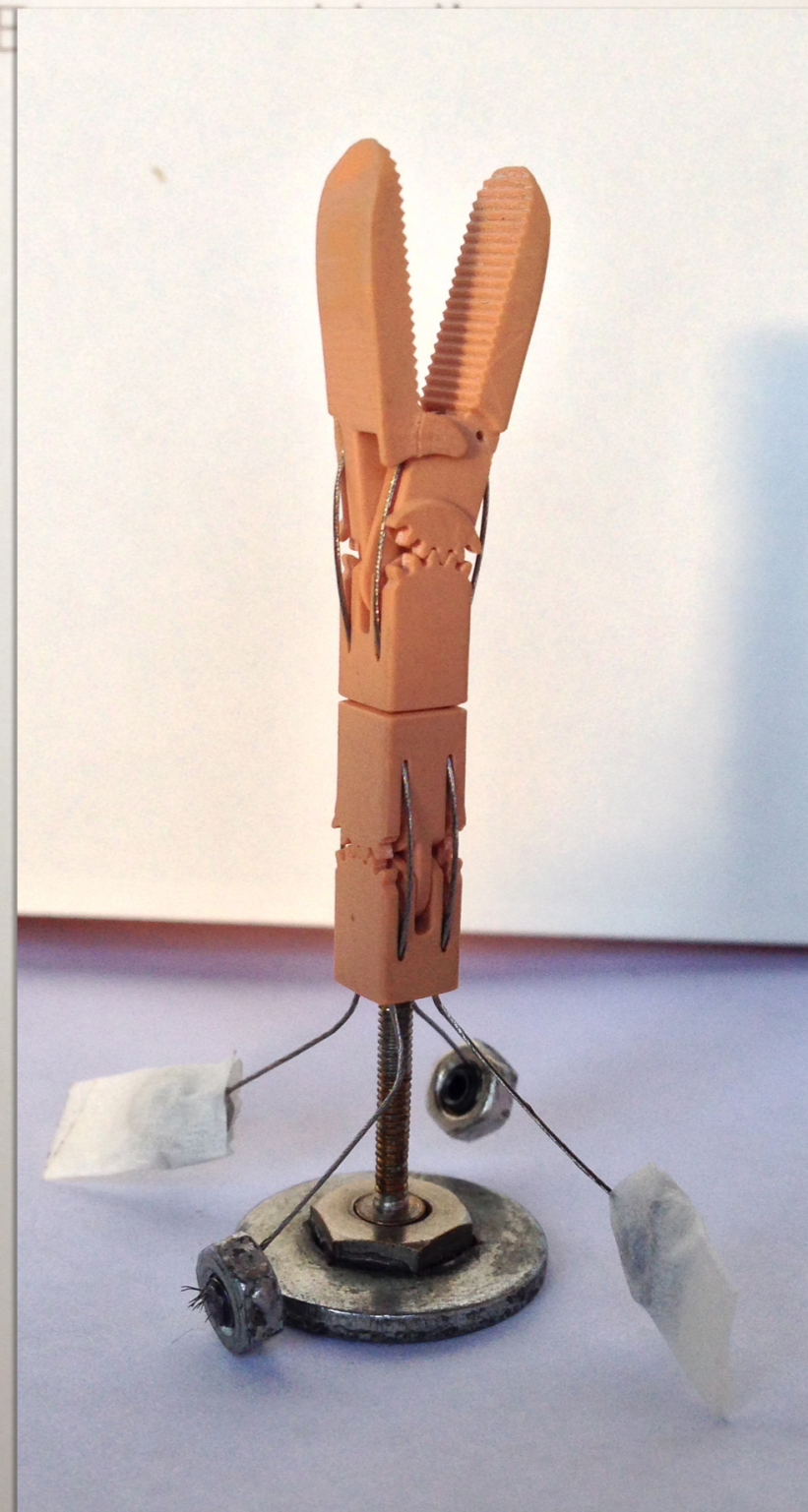
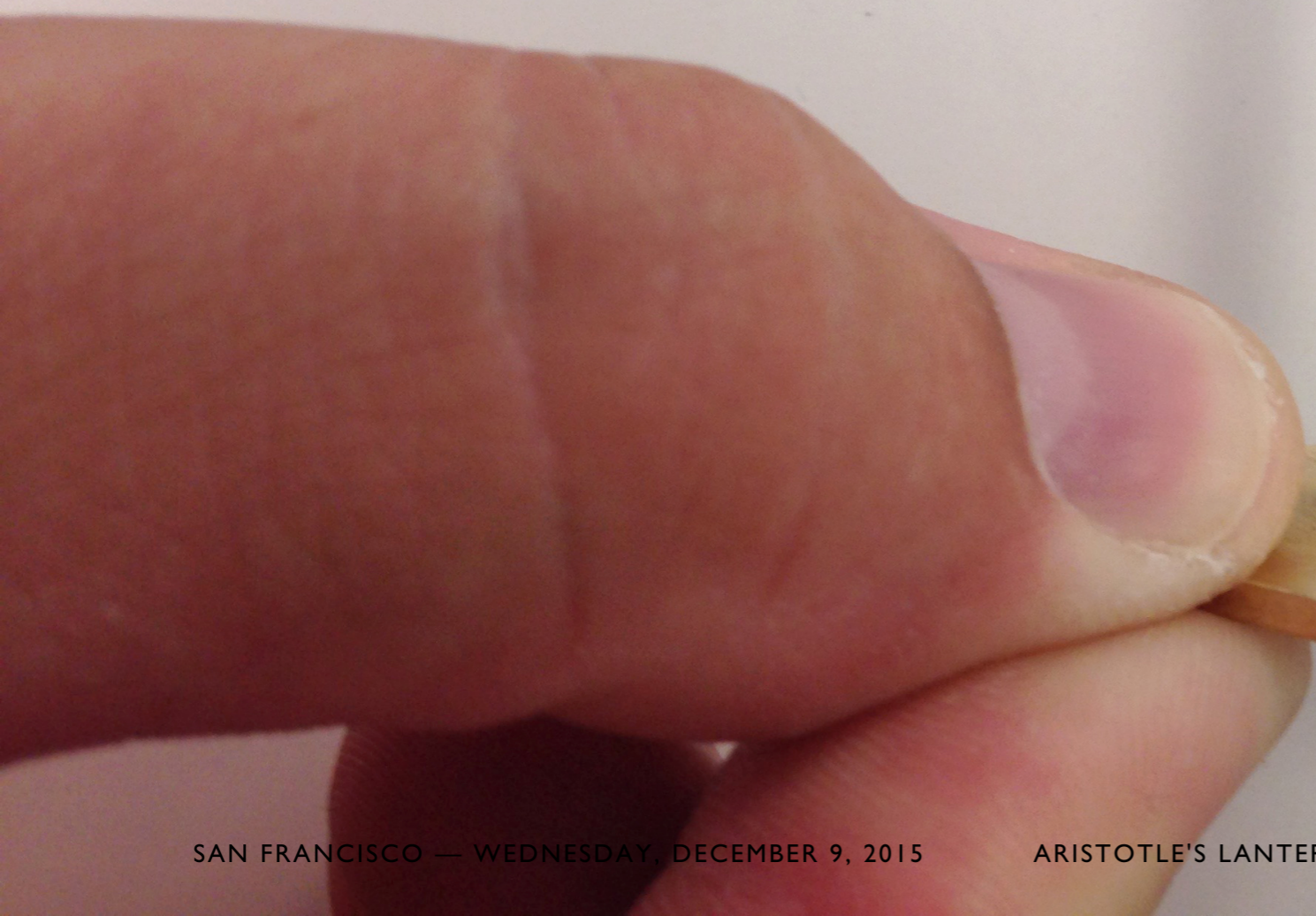



(Jelínek, Smit, Breedveld, UT Delft, 2014)

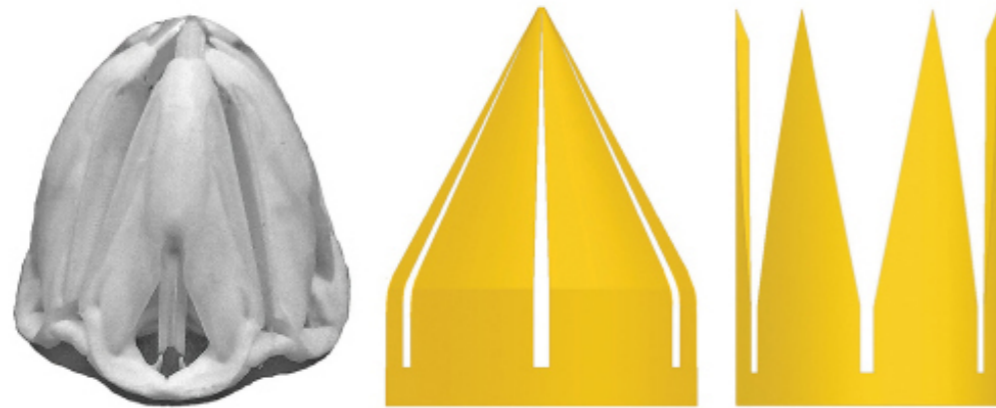
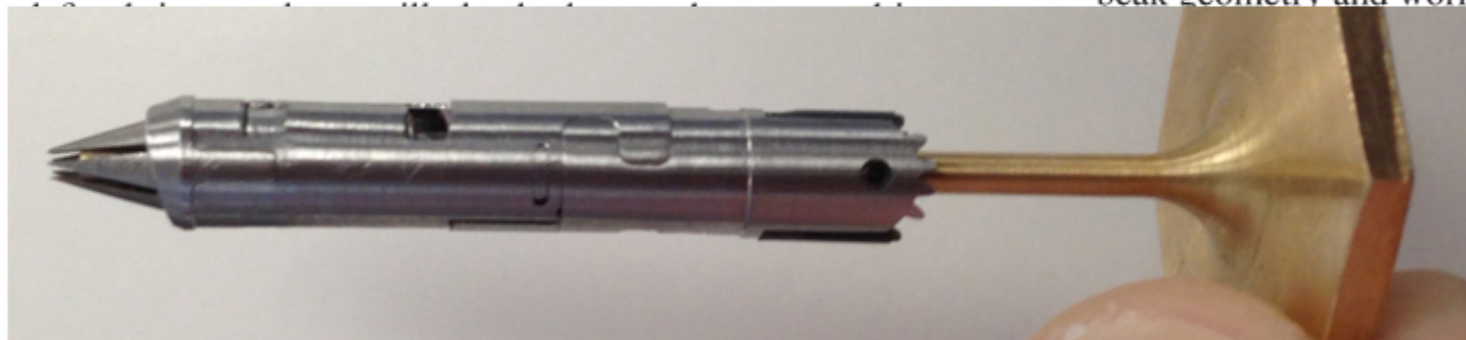

Fig. 4 Sea urchin's chewing organ, Aristotle's lantern—left—providing an inspiration to the biopsy harvester's crown-shaped collapsible cutter (collapsed—center, at rest—right)

round, crown-shaped collapsible cutter was designed (Fig. 4, right), physically resembling Aristotle's lantern and enabling simultaneous tissue incision and enclosure. Since any hinged features would likely lack sturdiness at this scale, not to mention their manufacturing feasibility, the cutter had to be designed thin enough as to allow the collapsibility of the blades and thus the enclosure of the sampled tissue. Six symmetrical blades were chosen as optimal both for manufacturing feasibility and for creating a seemingly straight blade cross section for easy inward bending, while keeping the blade profiles wide and strong enough to prevent outward bending when retracted.



perfect tissue incision with biopsy retrieval in a single tool or procedure. Since accurate, laparoscopic, frontally acting biopsy har-

Propulsion—Pilot Cutter Experiments. The sea urchin's beak geometry and working principle were recognized as essential for the biopsy harvester, combining frontal cutting and tissue enclosure. However, together with its muscle and complex structure, it was difficult to replicate in a miniature and simple design. It has been decided to modify the crown-shaped cutter so that it would close automatically by force. Furthermore, to gain further insight and inspiration into the cutter actuation, an in vitro experiment was performed in the Tensile Testing Lab of our department. Its goal was to find out what forces such a cutter encounters during tissue penetration and to test its cutting capabilities. The crown-

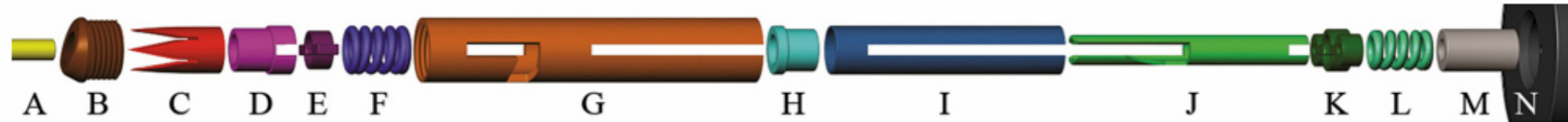

Fig. 6 Exploded view of the spring-loaded biopsy harvester design with its 14 components (A–N), showing their mutual axial alignment

sea urchin's bulky exoskeleton. The beak bites through and encompasses even a very tough material, e.g., corals, by pressing the mutually fitting teeth together by axial translation, due to the basal attachment of the muscle tendons [22,23]. More specifically, Aristotle's lantern is open when protruding outwards and closed when retracted inwards. **As demonstrated by Giorgio Scarpa's bionic model of Aristotle's lantern [24,25], by this means, the sea urchin can simultaneously cut off and enclose its food in a seemingly unified and continuous motion.** The capability of the simultaneous tissue incision and enclosure by axial translation exactly fits the envisioned biopsy harvester's functionality needs. This is

protocol was followed with the cutting experiments performed on a single piece of chicken breast. The collapsing motion of the cutter blades was not yet taken into account in this experiment, i.e., the cutter stayed open.

The data from numerous push-in trials on chicken liver is plot-

(Jelínek, Smit, Breedveld, UT Delft, 2014)

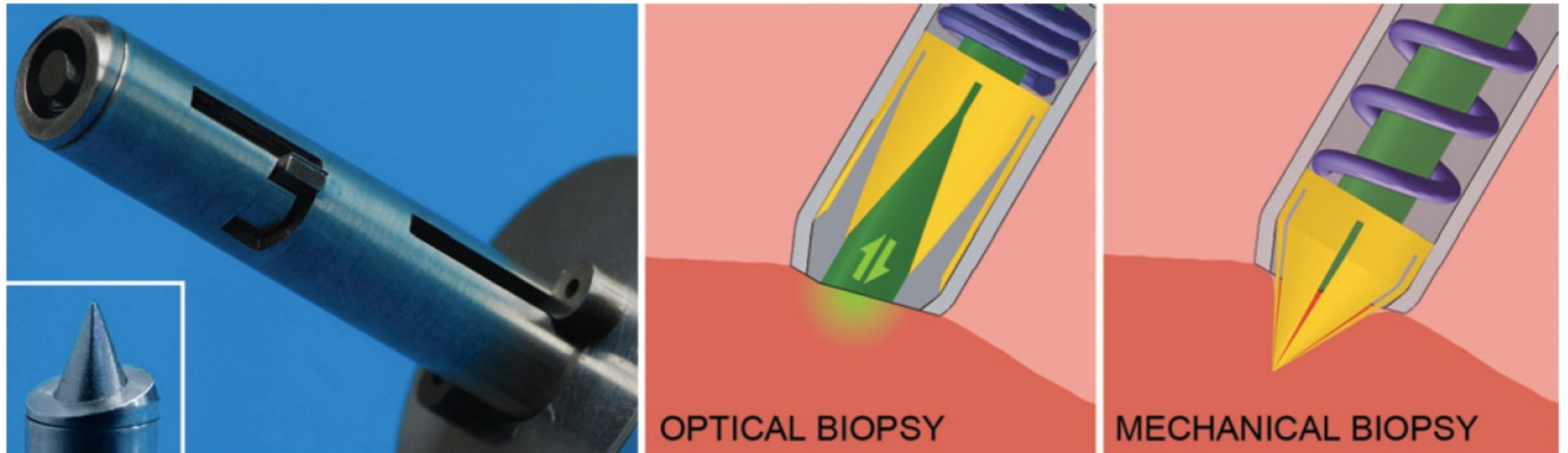
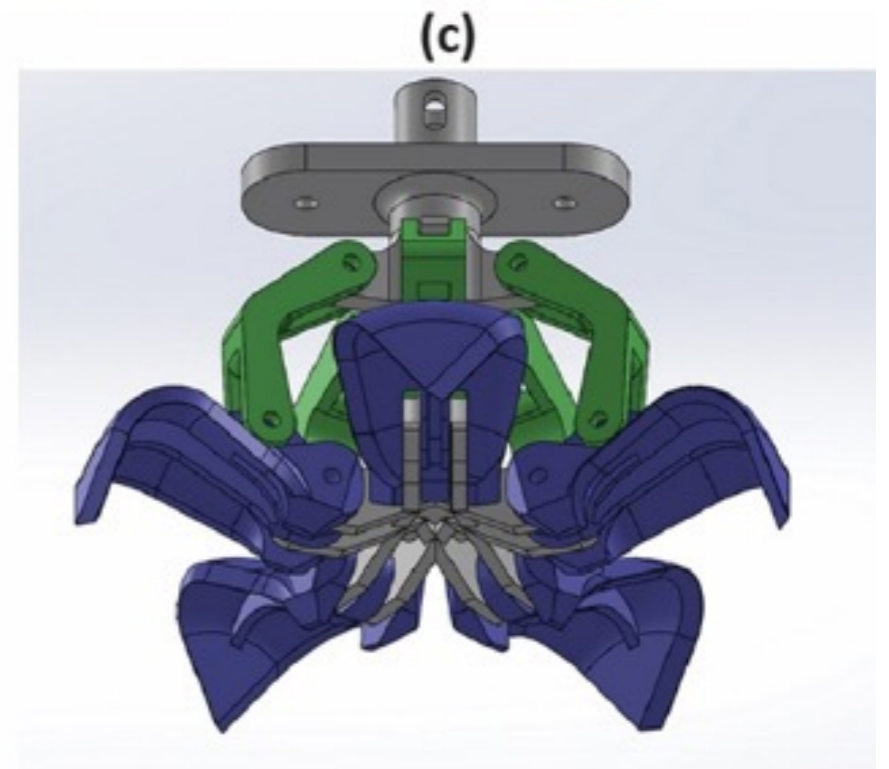
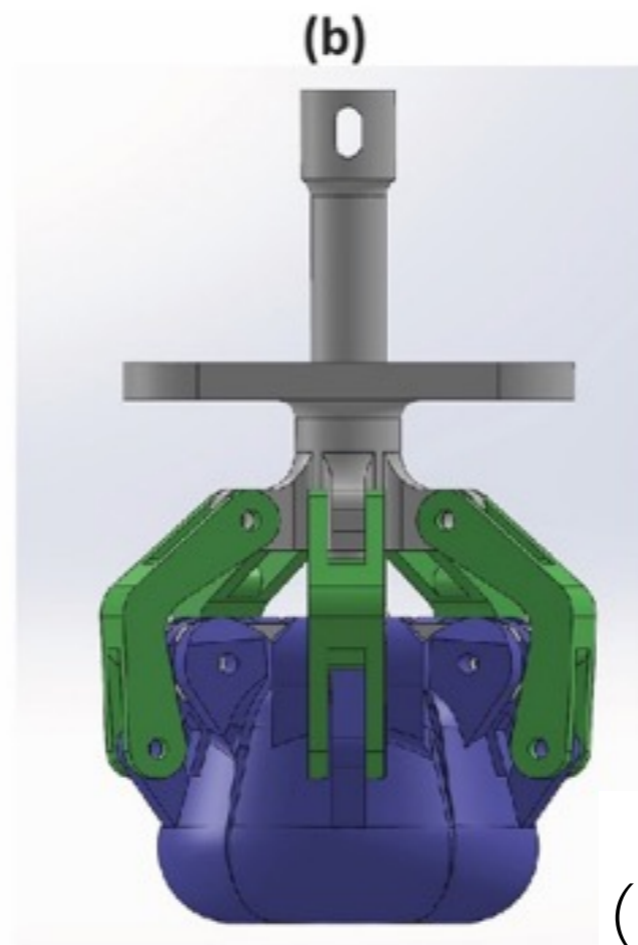
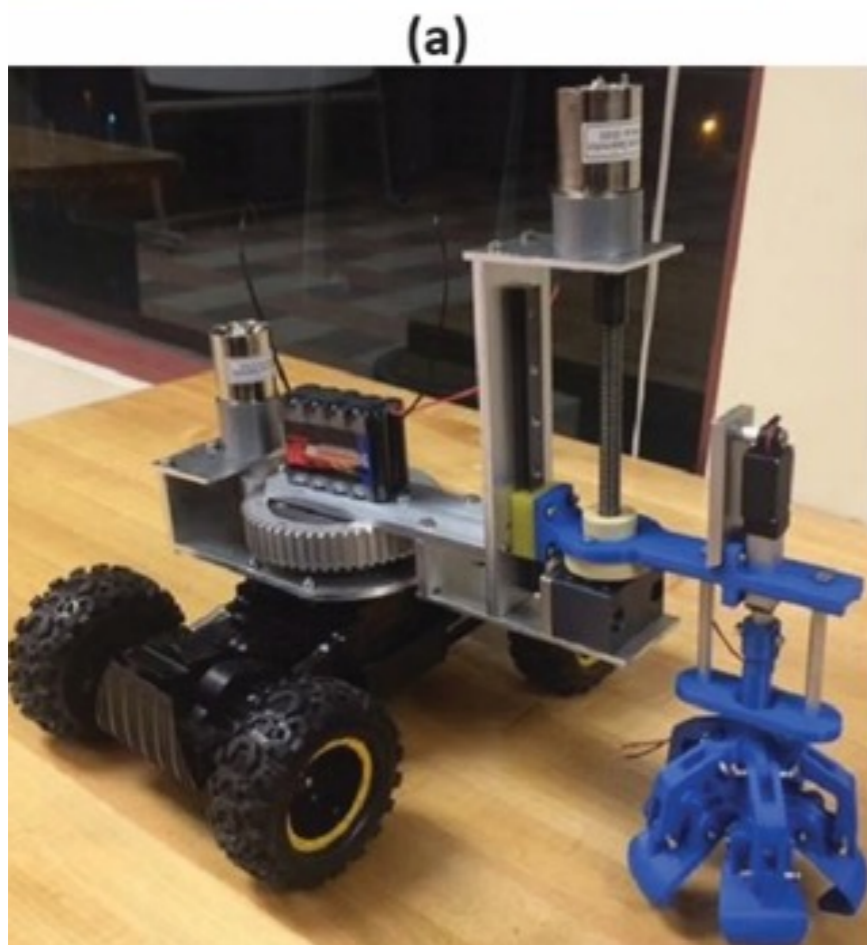
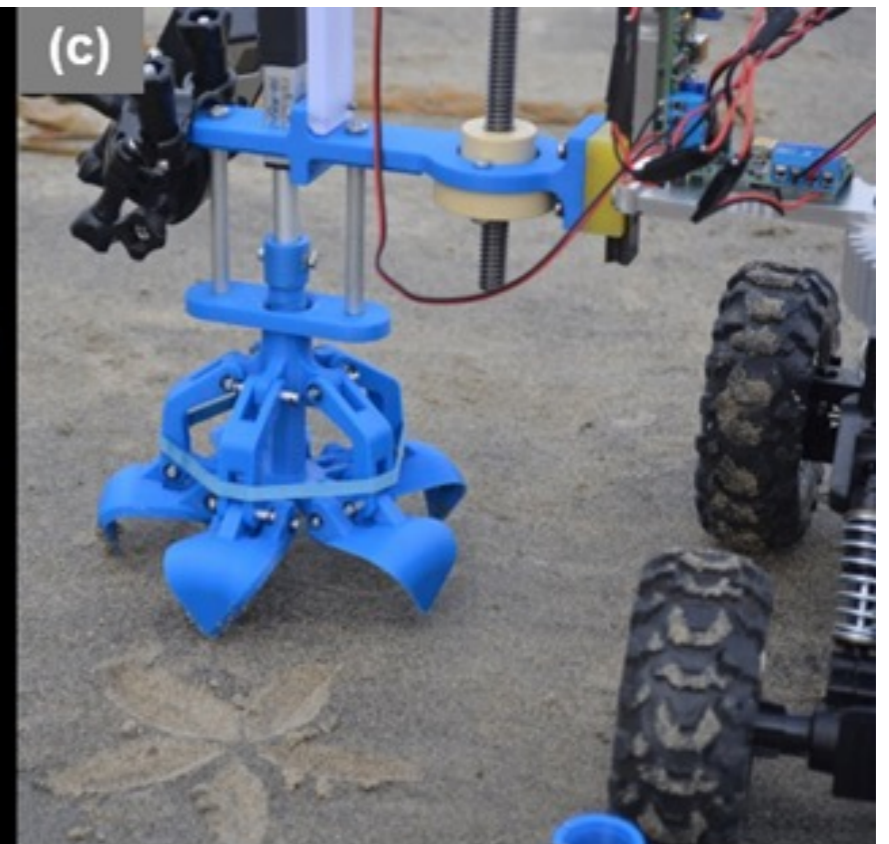
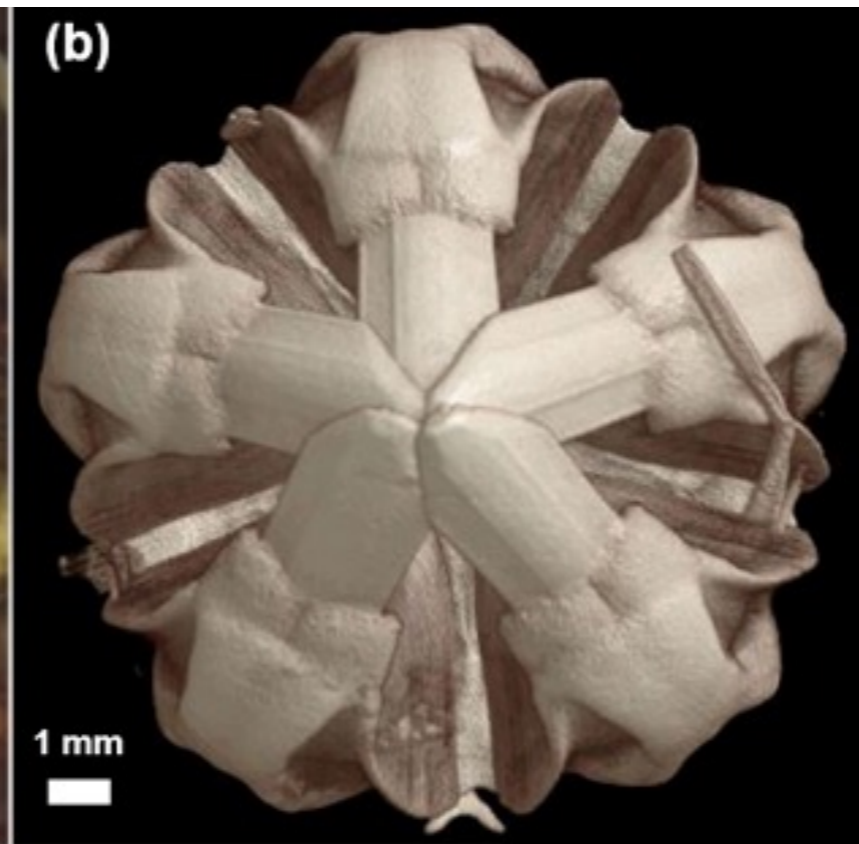
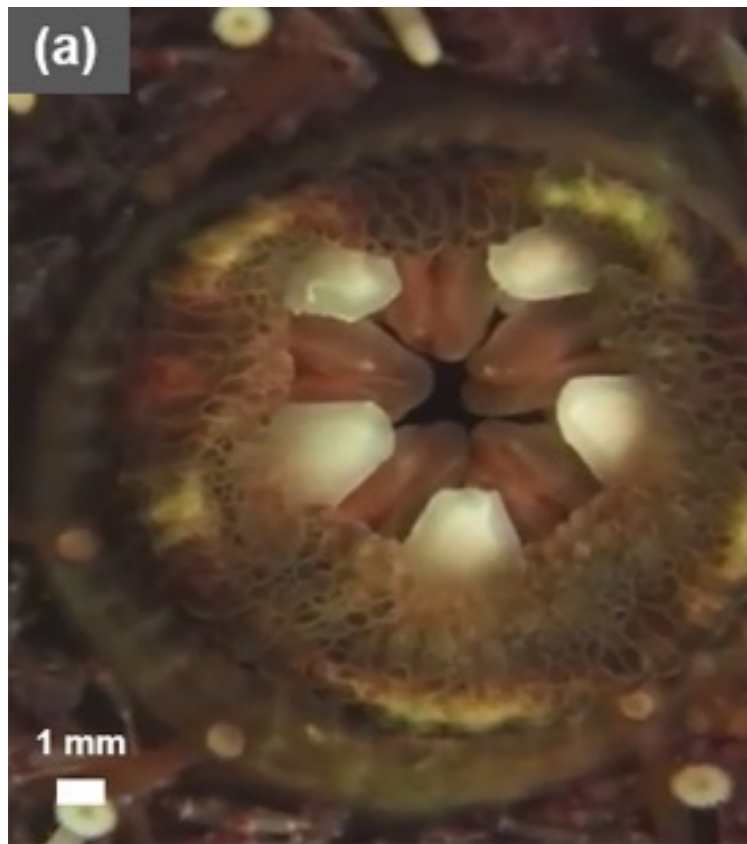
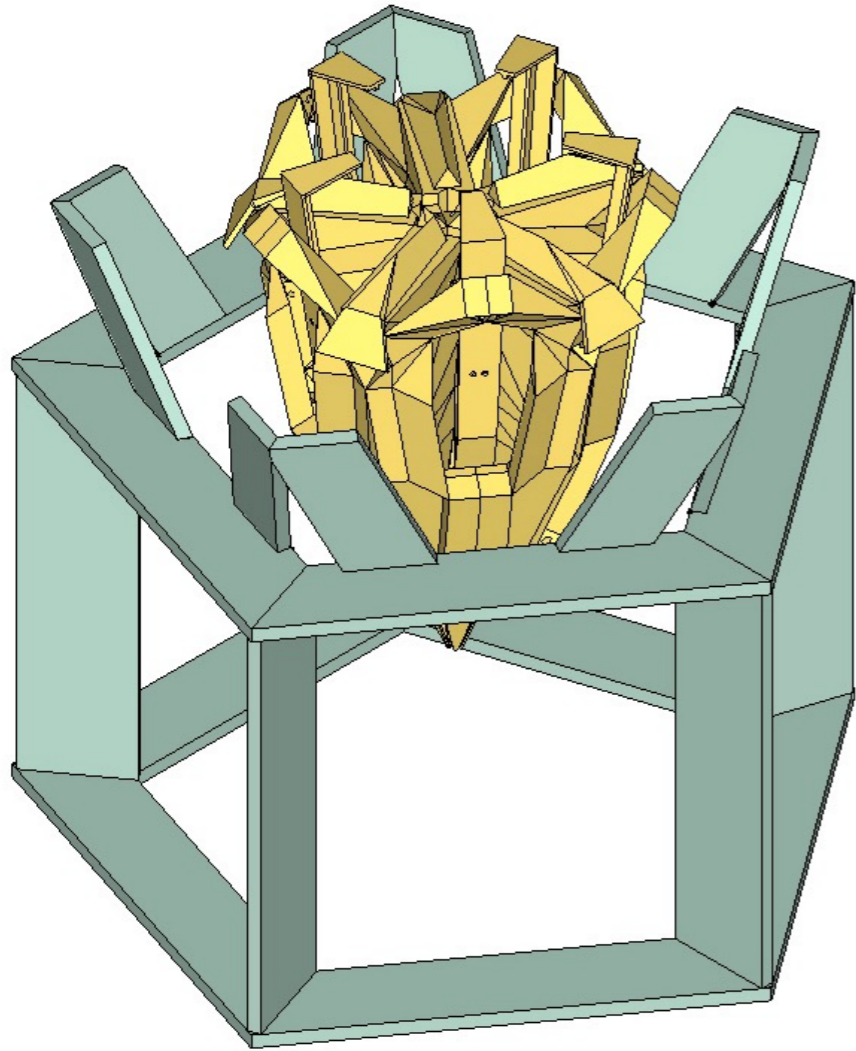

Fig. 2 Keyhole biopsy harvester [6] and its working principle combining optical and mechanical biopsy

(Jelínek, Smit, Breedveld, UT Delft, 2014)



(Frank et al, UC San Diego, 2015)



(Trogu – after Scarpa, 2014)

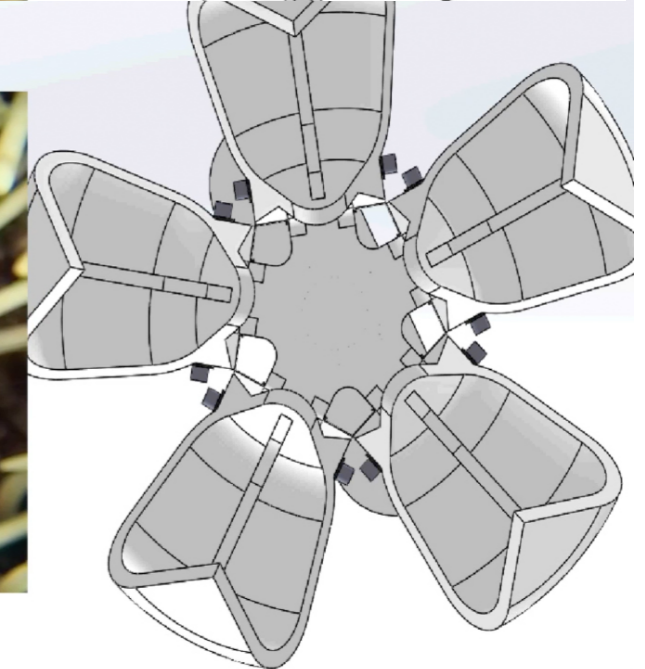
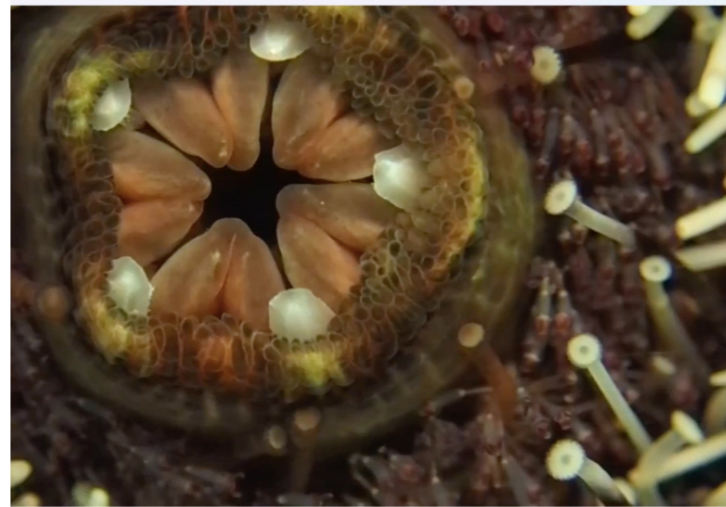
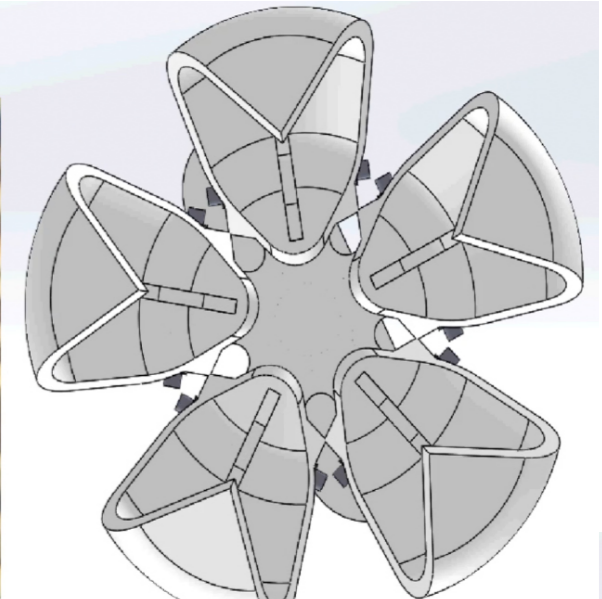
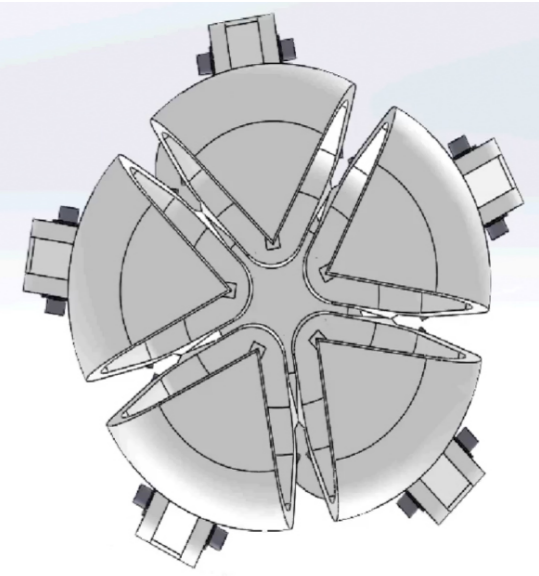

(Frank et al, UC San Diego, 2015)

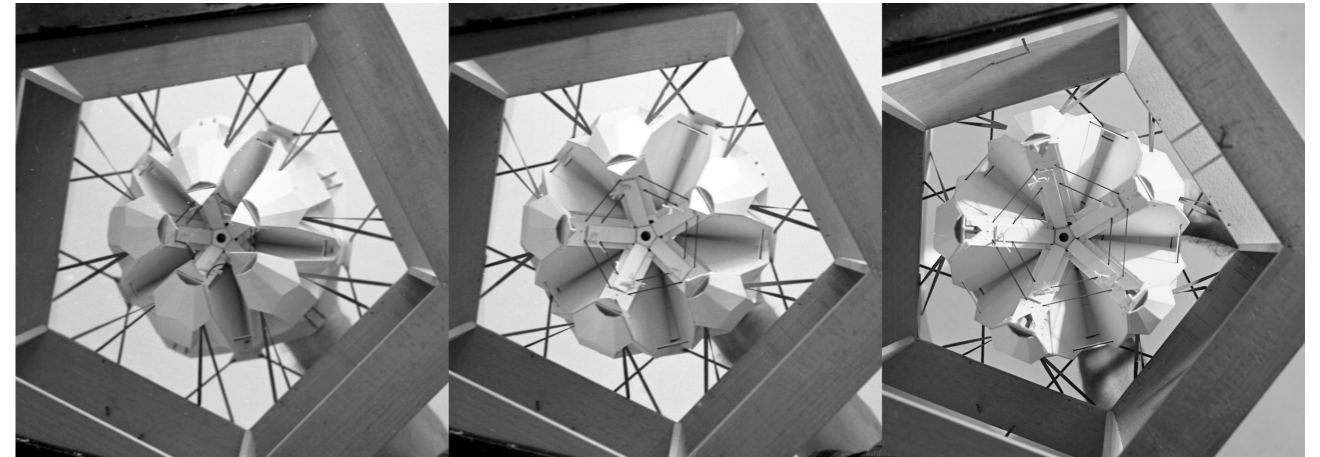
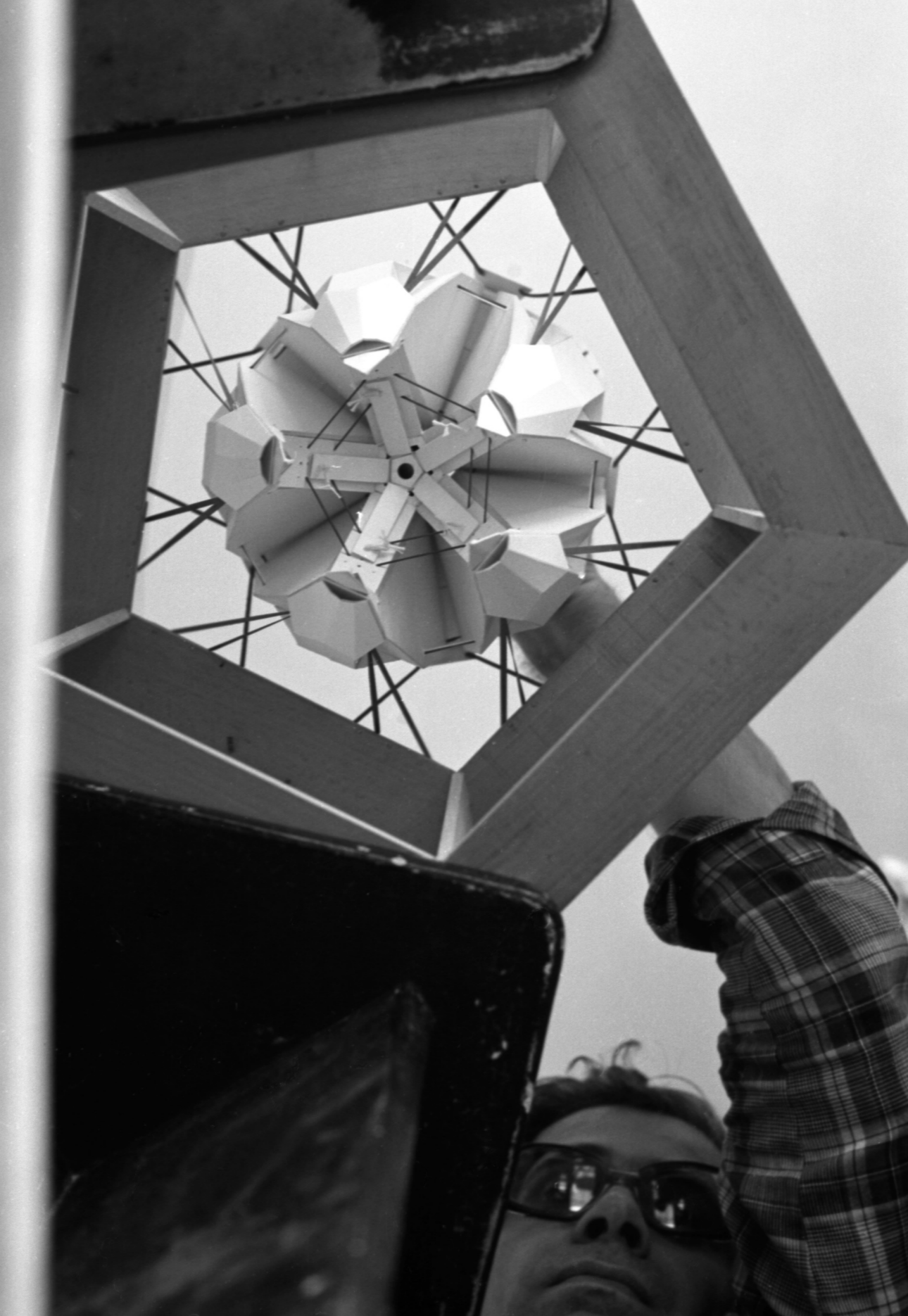
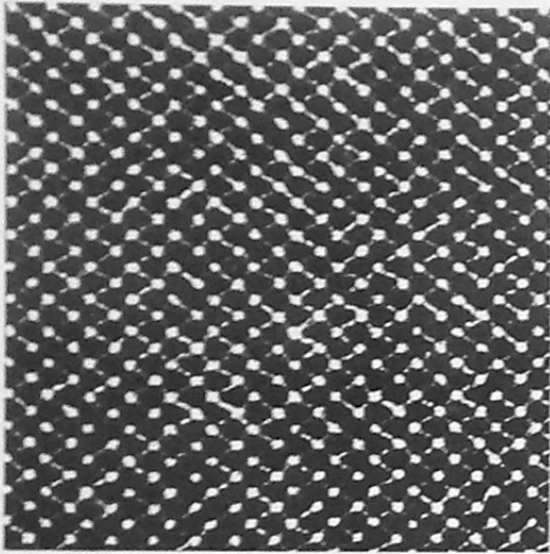
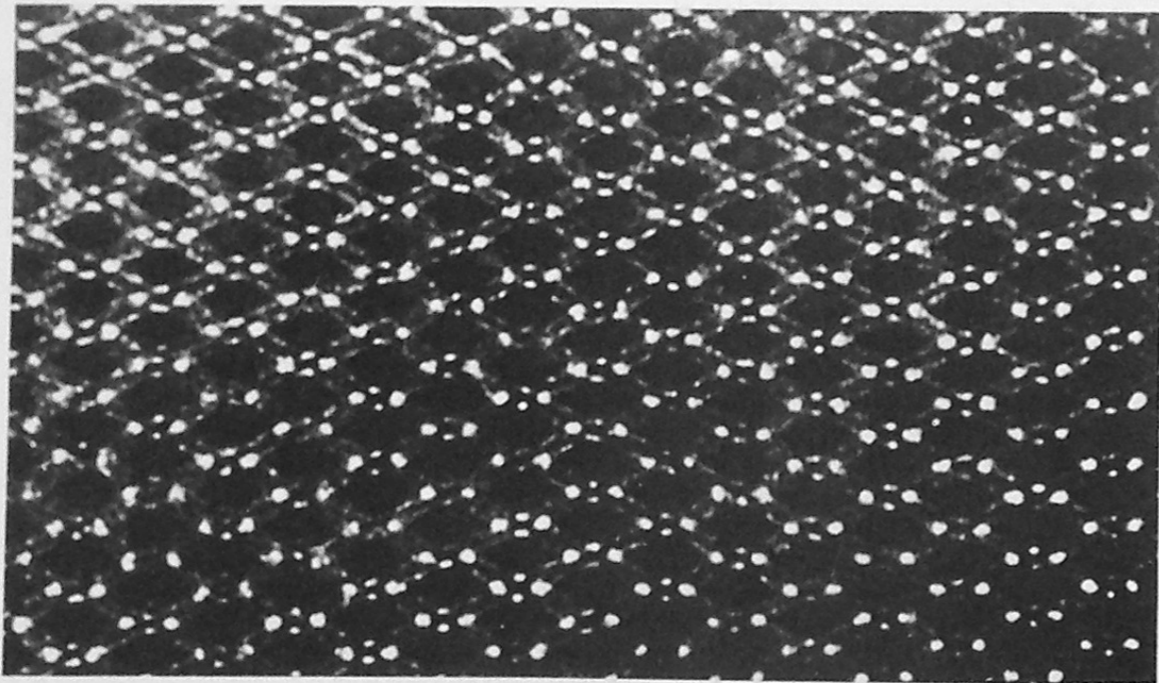

Photo: Giorgio Cireddu



Nella pagina a fianco, 25 catene ad anello, 150 coppie, 300 moduli, formano questo ordinamento spaziale visto in proiezione orizzontale.

Cristallo di tropomiosina. La microfotografia è una proiezione in un piano di un reticolo tridimensionale costituito da filamenti molecolari connessi trasversalmente e ingranditi 200 000 volte.



Microfotografia di una rete a doppio rombo di una fibra muscolare.

94

Modelli di geometria rotatoria, pp. 94-95

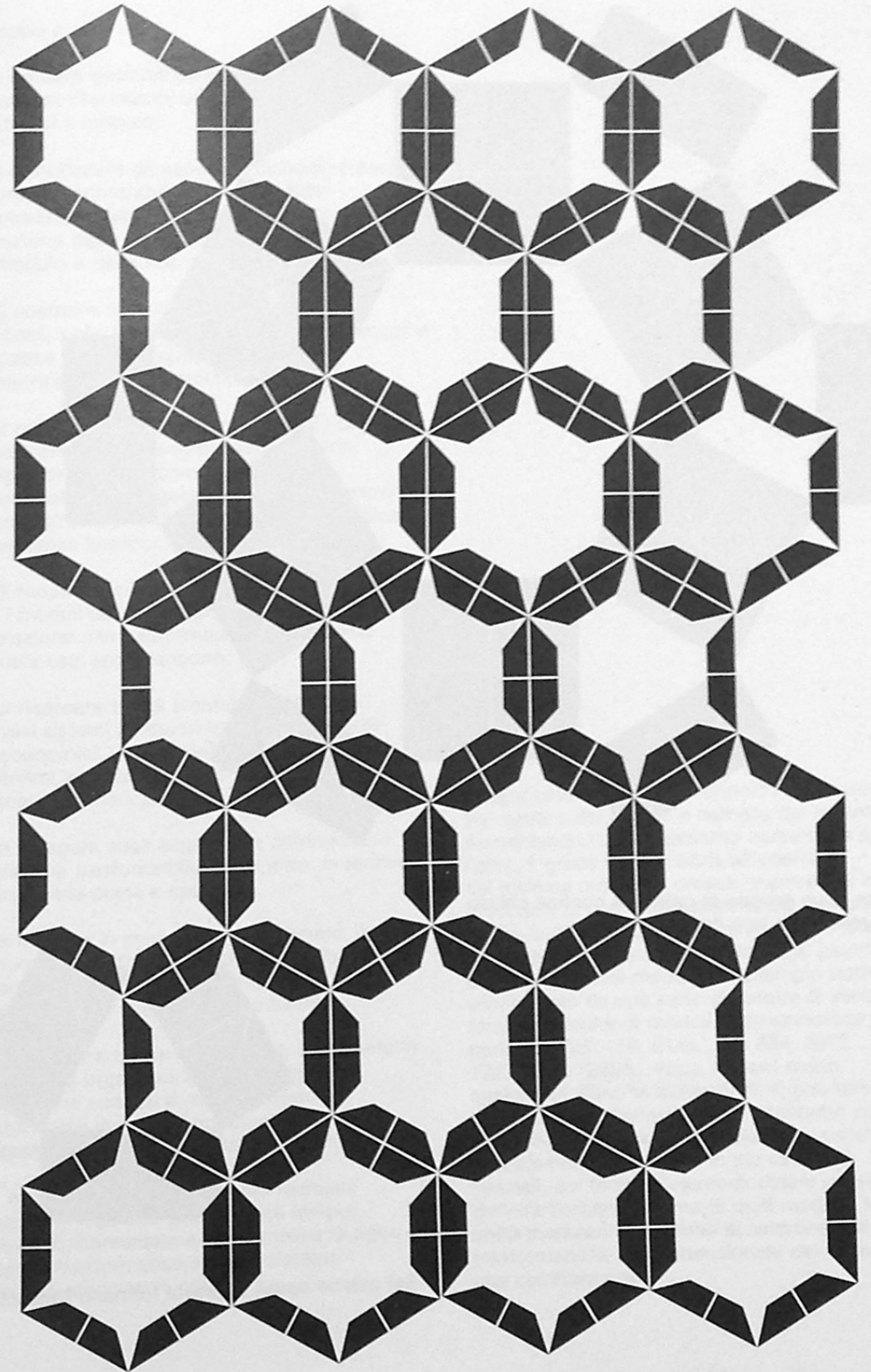

95

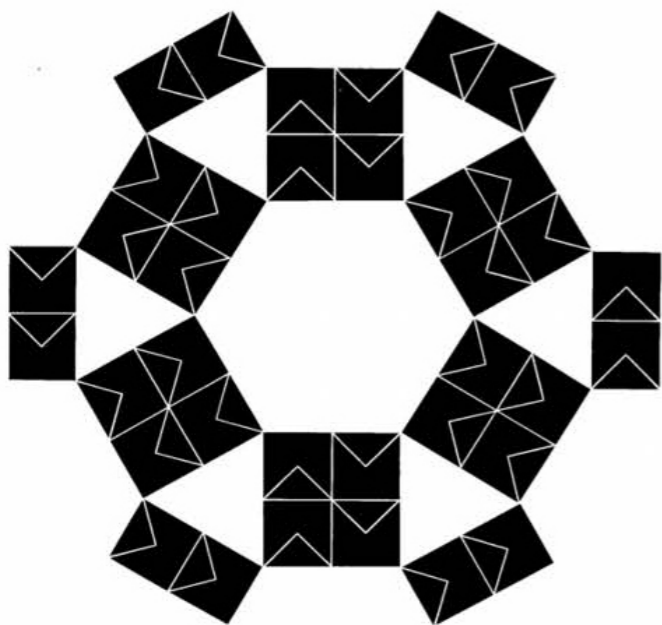
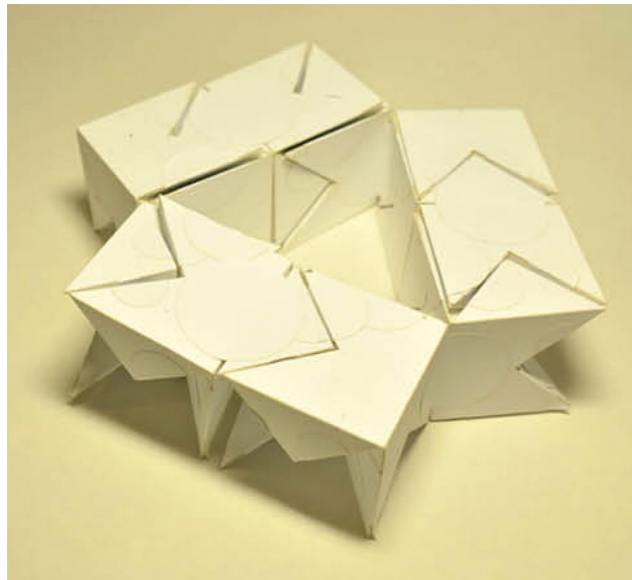

Modelli di
geometria rotatoria, p. 96

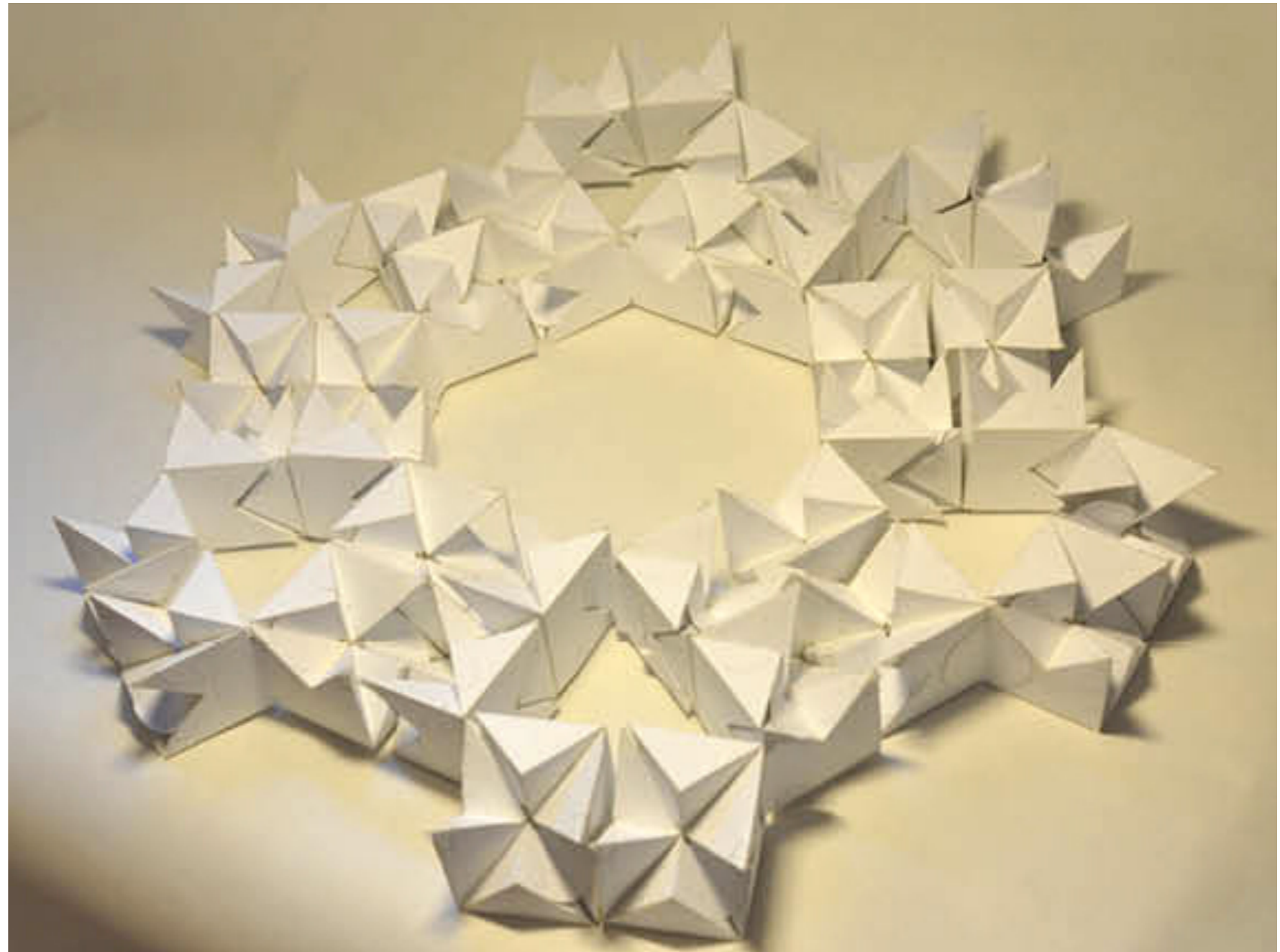

(Prototype of proposed extended model,
Trogu & Nies, , 2015)



Giorgio Cireddu

International Society for Medical Innovation and Technology, iSMIT 2016, Delft, Olanda



Design of Medical Devices DMD EU 2016, Delft, Olanda



[trogu SFSU urchin side-by-side video](#)



[jelínek UT DELFT dragonflex video](#)

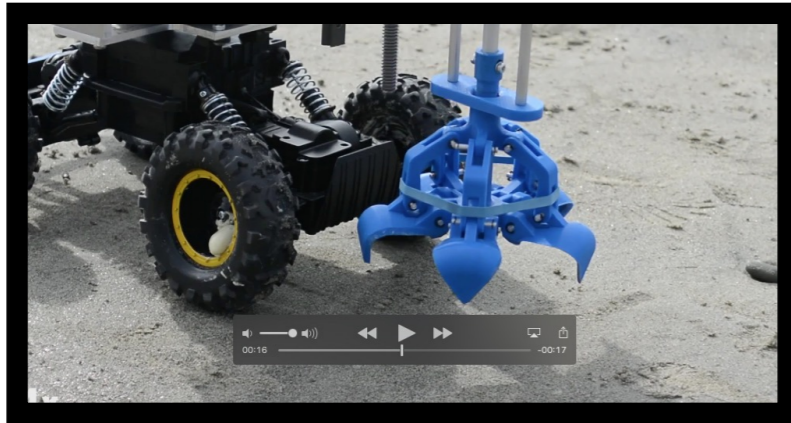

[frank UCSD mars rover video](#)

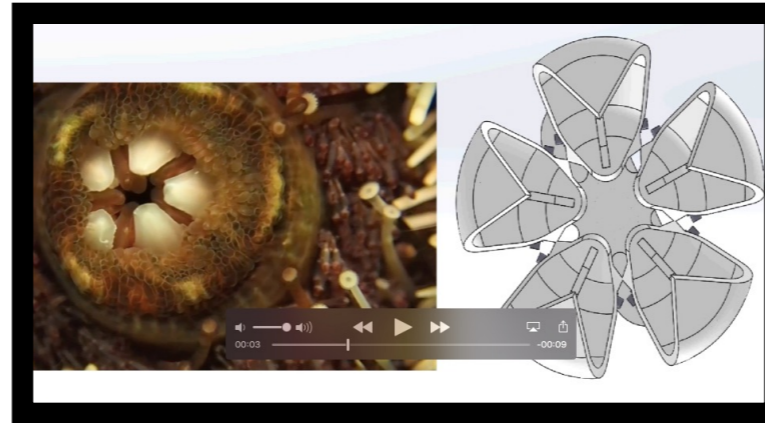

[frank UCSD urchin side-by-side video](#)



[scarpa lanterna aristotele video](#)



[scarpa "poi mi dimentico" video](#)

VIDEO

Two bioinspired instruments based on Giorgio Scarpa's model of a sea urchin: a biopsy harvester and a ground sampler

Pino Trogu

San Francisco State University

Abstract

Giorgio Scarpa (1938-2012) was an Italian teacher, designer, and artist who worked also in bionics, topology, and rotational geometry. This article describes Scarpa's bionic model of the mouth of the sea urchin, or "Aristotle's Lantern", built in the early 1970s and published in 1988 in *Modelli di Bionica*. Recently, the model has inspired separate experimental designs for a biopsy harvester and a mini-rover to collect soil samples on Mars. Today, the research literature on Echinoidea lacks a comparable study of the remarkable mouth mechanism. Scarpa's paper model is the only known physical analogue of the mechanism, and is a striking example of craftsmanship bridging art and science.

Bibliography

- 1 Scarpa, Giorgio, *Modelli di geometria rotatoria: i moduli complementari e le loro combinazioni*, Quaderni di design 5, ed. B. Munari, (Bologna: Zanichelli, 1978).
- 2 Scarpa, Giorgio, *Modelli di bionica: capire la natura attraverso i modelli*. Quaderni di design 13, ed. B. Munari, (Bologna: Zanichelli, 1985).
- 3 Marra, Claudio, "Un software naturale", introduction to the exhibit *Giorgio Scarpa: a natural software*, Ferrara, Art Institute "Dosso Dossi", (1987).
- 4 Klein, Jacobi T., *Naturalis Dispositio Echinodermatum*, (Leipzig: Officina Gleditschiana, 1734)
- 5 Aristotle, *Historia Animalium*, (Oxford: Clarendon Press, 1910)
- 6 Scarpa, Giorgio, *Bionic models: understanding nature through the use of models*. Design notebooks 13, trans. P. Trogu, <http://online.sfsu.edu/trogu/scarpa/pdf/bionic_models_complete.pdf> accessed 26 March 2015.
- 7 Trogu, Pino, "Bionic Model of Aristotle's Lantern: Giorgio Scarpa, 1985," <http://online.sfsu.edu/trogu/scarpa/movies/scarpa_bionics.mov>, accessed 22 March 2015
- 8 Carnevali, Maria D. C. and F. Andrietti, *The Aristotle's Lantern of the Regular Sea-urchins: a Striking Example of Form-function Relation and Adaptation*, in *Form and Function in Zoology* (Mucchi Editore: Modena, 1991), pp. 245-266.
- 9 Carnevali, Maria D. C. et al, "The Aristotle's Lantern of the Sea-urchin *Stylocidaris Affinis* (Echinoidea, Cidaridae): Functional Morphology of the Musculo-skeletal System," *Zoomorphology*, Vol. 113, No. 3, 173-189 (1993).

- 10 Jelínek, Filip, G. Smit, and P. Breedveld, “Bioinspired Spring-Loaded Biopsy Harvester—Experimental Prototype Design and Feasibility Tests,” *Journal of Medical Devices*, Vol. 8, No. 1, 015002-015002-6 (2014).
- 11 Frank, Michael et al., “A Protocol for Bioinspired Design: A Ground Sampler Based on Sea Urchin Jaws”, *The Journal of Visualized Experiments (JoVE)*, <<http://www.jove.com>> (forthcoming) accessed xx xxx xxxx.
- 12 Frank, Michael. “Sea Urchin Mouth and Mars Rover—Side by Side”, <http://static.trogu.com/documents/conference/2015_castelbolognese/movies/frank_urchin_side_by_side_final.mov>, accessed 27 November 2015.
- 13 Trogu, Pino, C. di Bartolo, and F. Lodato, “Bionics and Design: Pure and Applied Research”, workshop in *Living Machines 2015, The Third International Conference on Biomimetic and Biohybrid Systems*, T. Prescott and A. Mura, Eds, (Milan, Italy, 2014).
- 14 Trogu, Pino, “Giorgio Scarpa’s Model of Aristotle’s Lantern”, *Living Machines 2014* <http://unixlab.sfsu.edu/~trogu/scarpa/video/01_living_machines_2014-07-31_img_1145.mov> accessed 26 March 2015.
- 15 Trogu, Pino, “Giorgio Scarpa’s Model of Aristotle’s Lantern”, *Living Machines 2014*, <http://unixlab.sfsu.edu/~trogu/scarpa/video/02_living_machines_2014-07-31_img_1157.mov> accessed 26 March 2015.
- 16 Trogu, Pino, “Bioinspired Design: Aristotle’s Lantern and Models of Rotational Geometry by Giorgio Scarpa,” Abstracts, *Design of Medical Devices Conference (DMD EU 2015)*, Wiener Neustadt, Austria, Sept. 8–9, 2015.
- 17 Ellers, Olaf and M. Telford, “Muscles Advance the Teeth in Sand Dollars and Other Sea Urchins,” *Proceedings of the Royal Society B: Biological Sciences*, London, Vol. 264, No. 1387, 1525-1530 (1997).
- 18 Killian, Christopher et al., “Self-Sharpening Mechanism of the Sea Urchin Tooth,” *Advanced Functional Materials*, Vol. 21, No. 4, 682-690 (2011).
- 19 Wilkie, I.C., C. Carnevali, and F. Bonasoro, “The Compass Depressors of *Paracentrotus Lividus* (Echinodermata, Echinoidea): Ultrastructural and Mechanical Aspects of their Variable Tensility and Contractility,” *Zoomorphology*, Vol. 112, No. 3, 143-153 (1992).
- 20 Jelínek, Filip et al., “Bioinspired Crown-Cutter—The Impact of Tooth Quantity and Bevel Type on Tissue Deformation, Penetration Forces, and Tooth Collapsibility,” *Journal of Medical Devices*, Vol. 8, No. 4, 041009-041009 (2014).
- 21 Jelínek, Filip, R. Pessers, and P. Breedveld, “DragonFlex: Smart Steerable Laparoscopic Instrument,” <http://static.trogu.com/documents/conference/2015_castelbolognese/movies/jelinek_vienna_2015-09-09_dragon-flex.mov> accessed 27 November 2015.
- 22 Jelínek, Filip, R. Pessers, and P. Breedveld, “DragonFlex: Smart Steerable Laparoscopic Instrument,” *Journal of Medical Devices*, 2014. Vol. 8, No. 1, 015001-015001-9 (2014).
- 23 Jelínek, Filip, “Steering and Harvesting Technology for Minimally Invasive Biopsy. Ph.D. dissertation, Chapter 9: *Discussion*, (UT Delft, 2015), 123–138.
- 24 Klee, Paul, *Notebooks Volume 2: The Nature of Nature*, (New York: Wittenborn, 1962) p. 6.
- 25 Scarpa, Giorgio, *Bionics: Exploration between play and research*. Unpublished notes, (Oristano: Italy, c. 1970).
- 26 Klee, Paul, *Notebooks Volume 1: The Thinking Eye*, (New York: Wittenborn, 1959) p. 127.

THANK YOU!

PINO TROGU – SAN FRANCISCO STATE UNIVERSITY, USA

ARISTOTLE'S LANTERN

TWO BIOINSPIRED DESIGNS

BASED ON GIORGIO SCARPA'S MODEL OF A SEA URCHIN:

A BIOPSY HARVESTER AND A GROUND SAMPLER



Giorgio Scarpa
Pino Trogu
Castel Bolognese, 1988

Acknowledgements

Thanks to Oda de Sisti, Lorenzo Bocca, Francesco Trogu, Antonio Cirezza, Silvan Linn, and Richard Ortiz for assistance with building the urchin replica, and to Giorgio Cireddu for photographs of the model and specimens.

PDF of slides, videos, and handout:

http://www.trogu.com/Documents/conference/2015_SFSU

Contact trogu@sfsu.edu

[go to first slide](#)