

PINO TROGU – SAN FRANCISCO STATE UNIVERSITY, USA

GIORGIO SCARPA

L'ATTUALITÀ DELLA RICERCA DI SCARPA
NELL'AMBITO TECNICO-SCIENTIFICO

CASTEL BOLOGNESE, RAVENNA, ITALIA

SABATO 21 NOVEMBRE 2015

[go to last slide \(p.39\)](#)

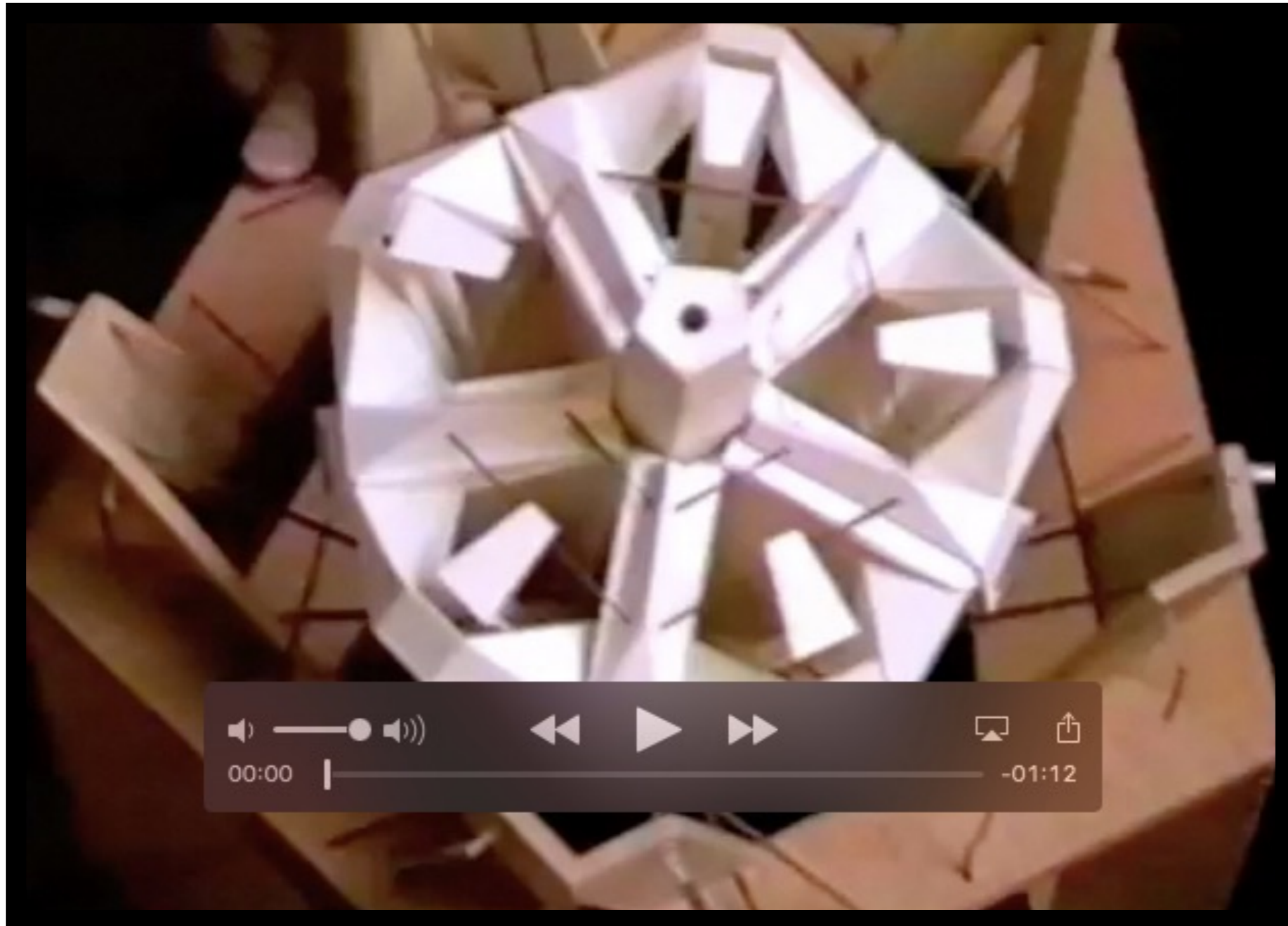

[scarpa lanterna aristotele video](#)





Foto: Giorgio Cireddu





Foto: Giorgio Cireddu

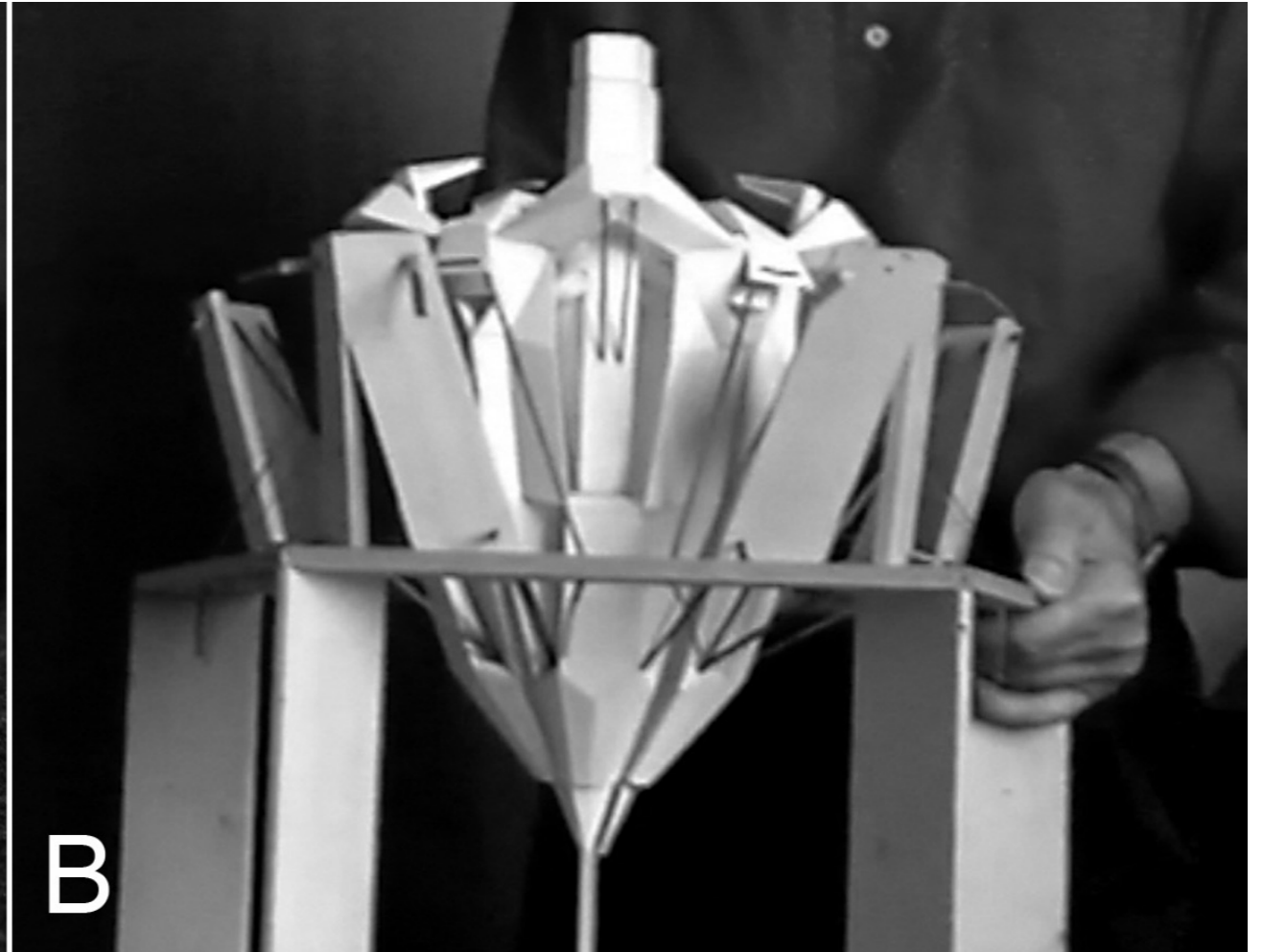

Foto: Giorgio Cireddu

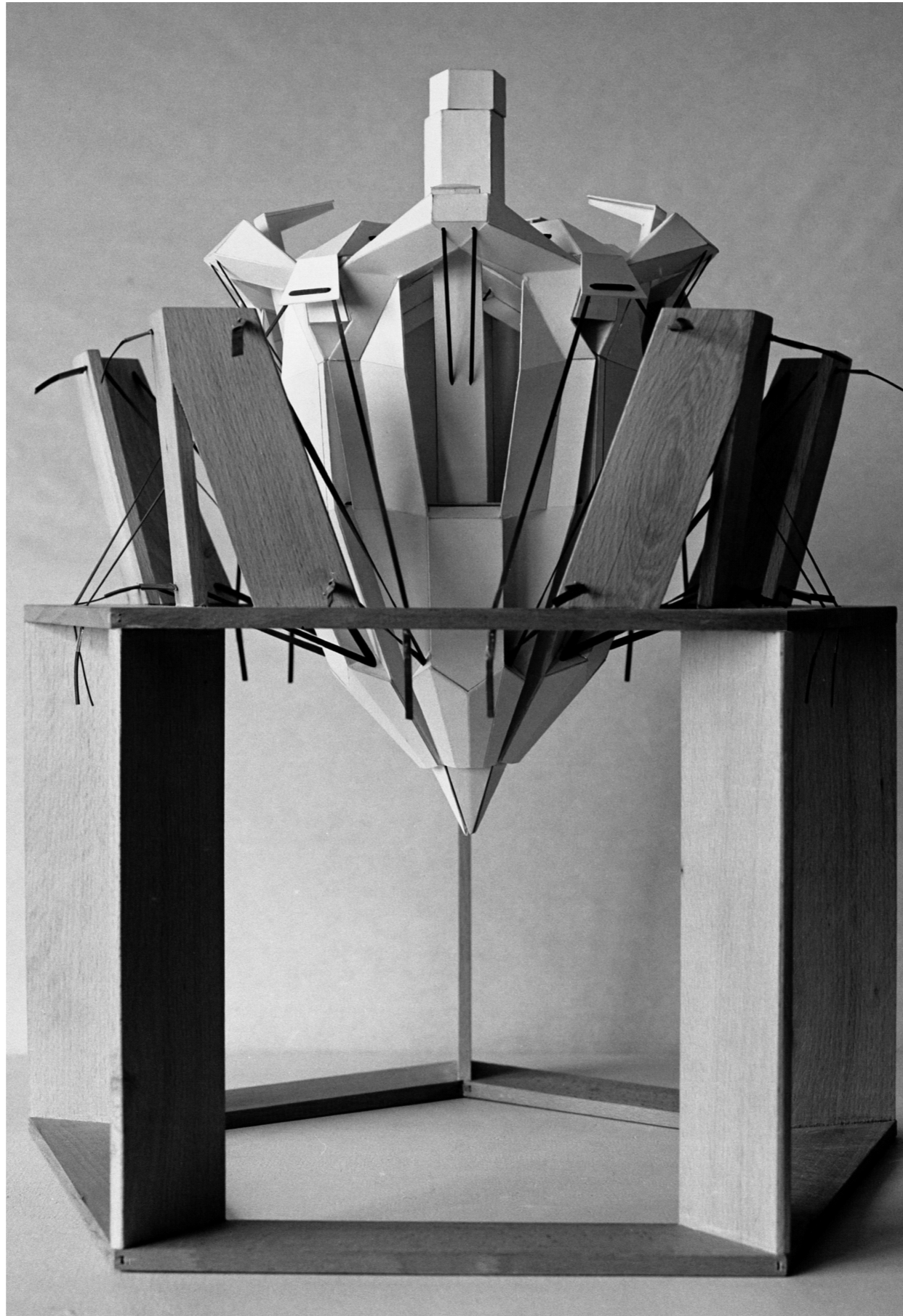

Foto: Pino Trogu

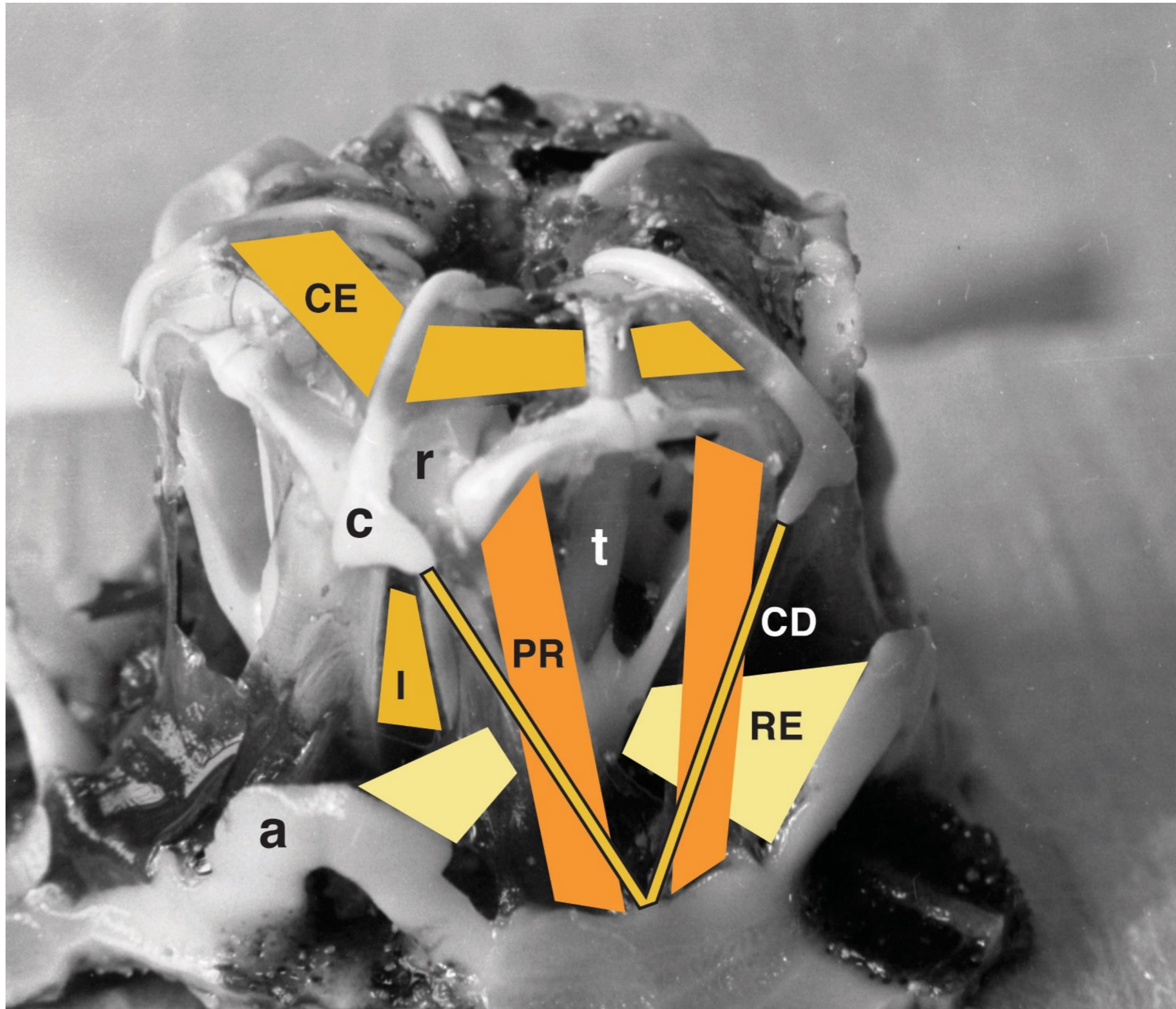

Foto: Giorgio Cireddu

Living Machines 2014

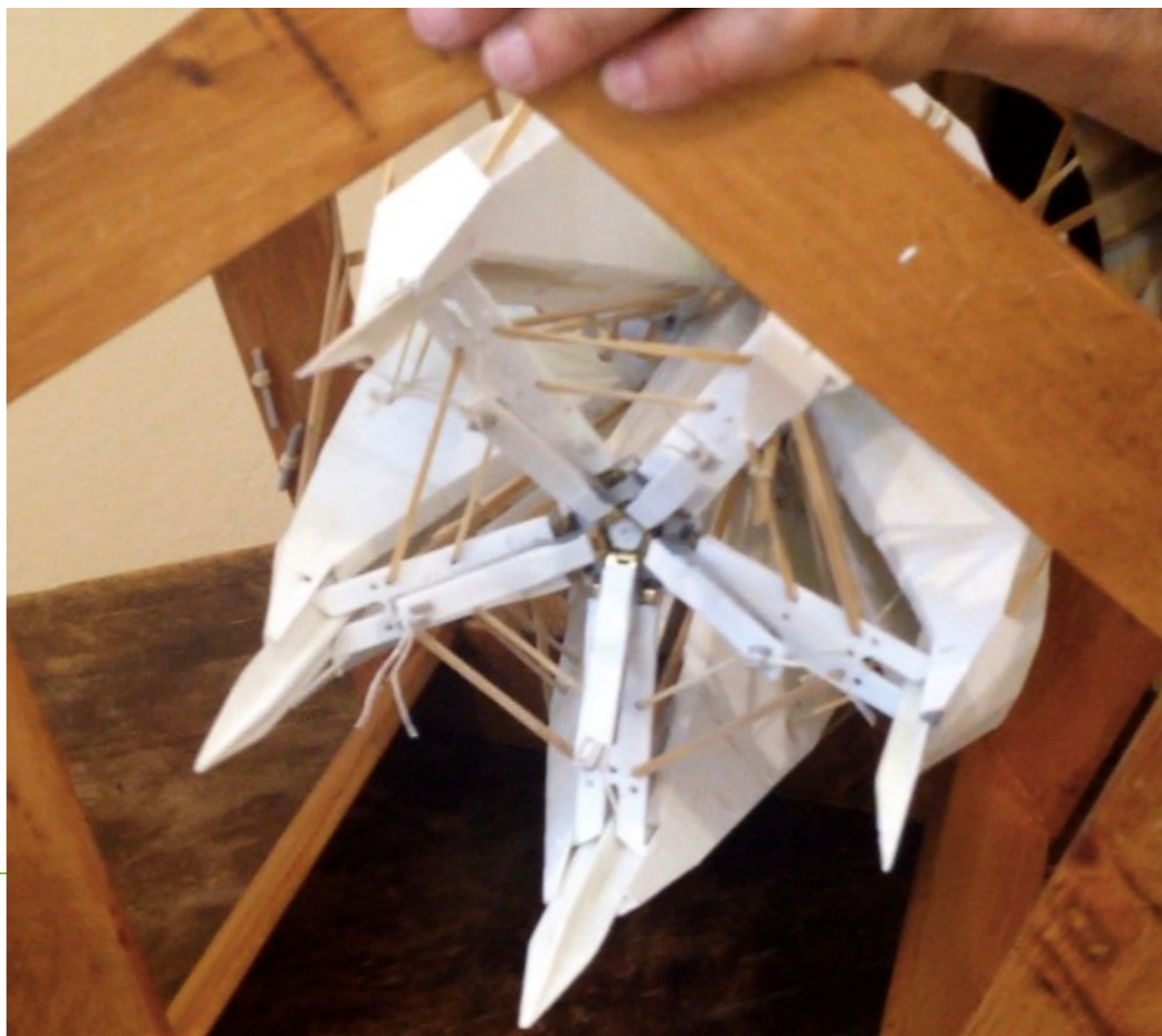
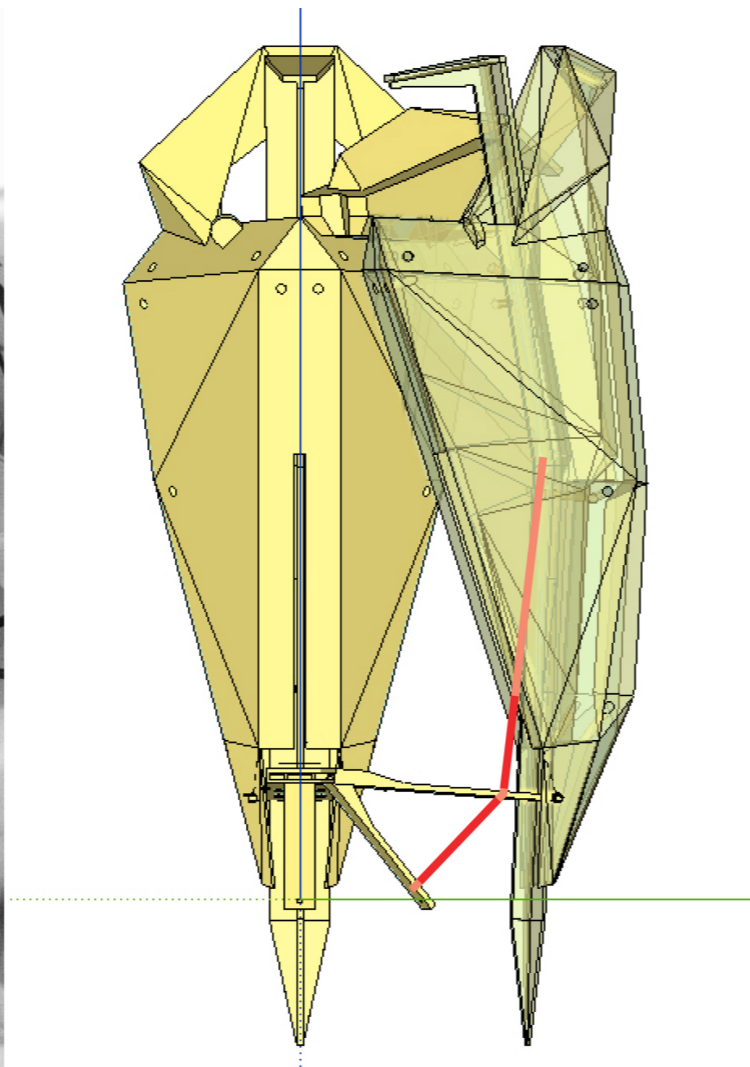
30 July-1 Aug.

Museo Nazionale
della Scienza e
della Tecnologia
Leonardo da Vinci,
Milano

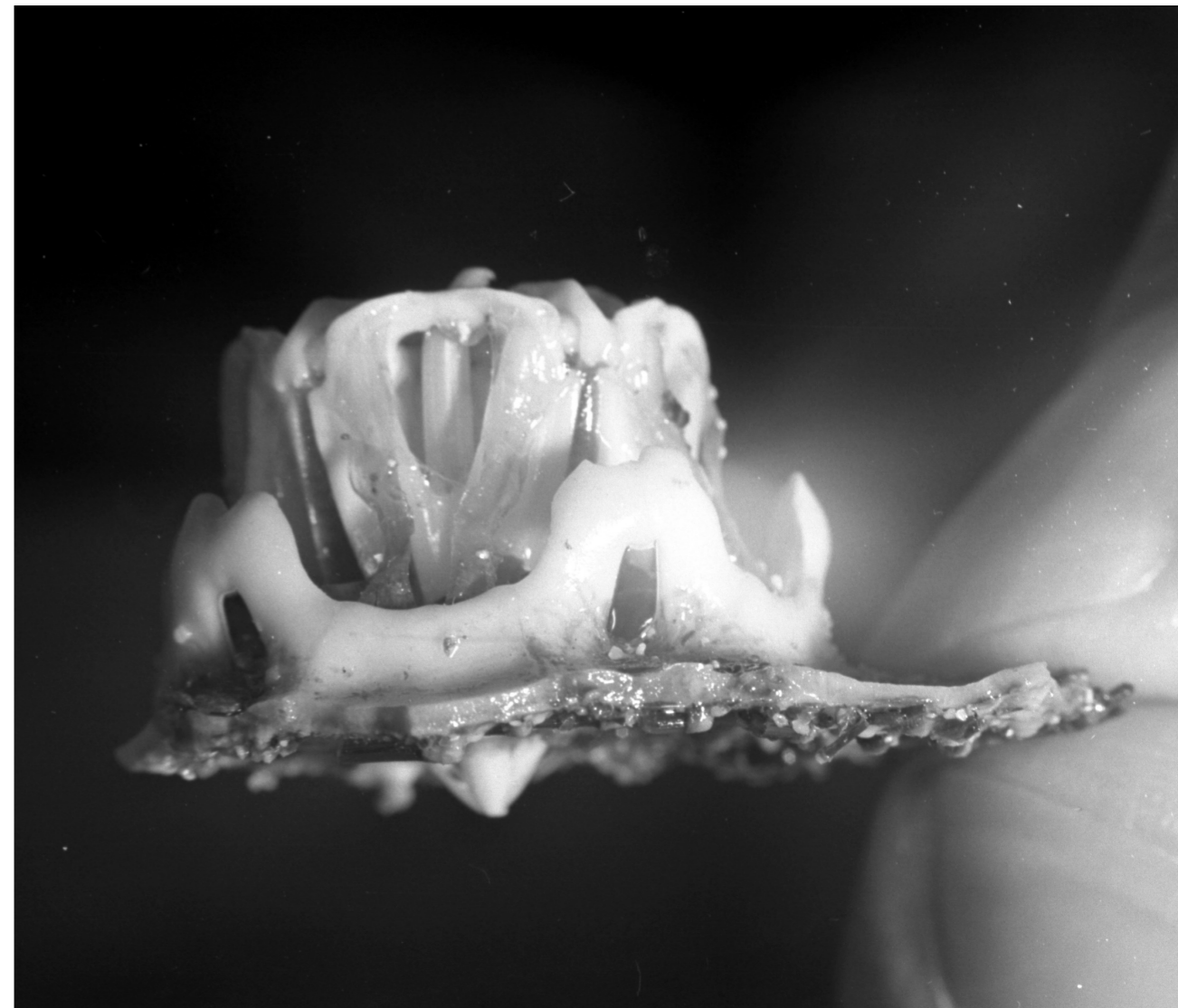
The 3rd Conference on Biomimetic and Biohybrid Systems

on!

Conference

- About
- Plenary talks
- Programme
- Submission

Committees

Venue

Registration

- Scholarships

Accommodation

Workshops

LM Editions

Contact

LM2015 photos



Supported by

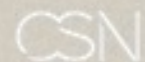

Welcome to Living Machines 2014



Lorenzo Bocca & Pino Trogu



Francesco Trogu

Living Machines 2014, Milano



Francesco Trogu

Museo della scienza e della tecnica, Milano, 2014

Europe Edition
September 8-9 2015, Austria
Vienna / Wiener Neustadt

Design of Medical Devices conference



www.designofmedicaldevices.eu



Air France SFO → Paris

Filip Jelínek

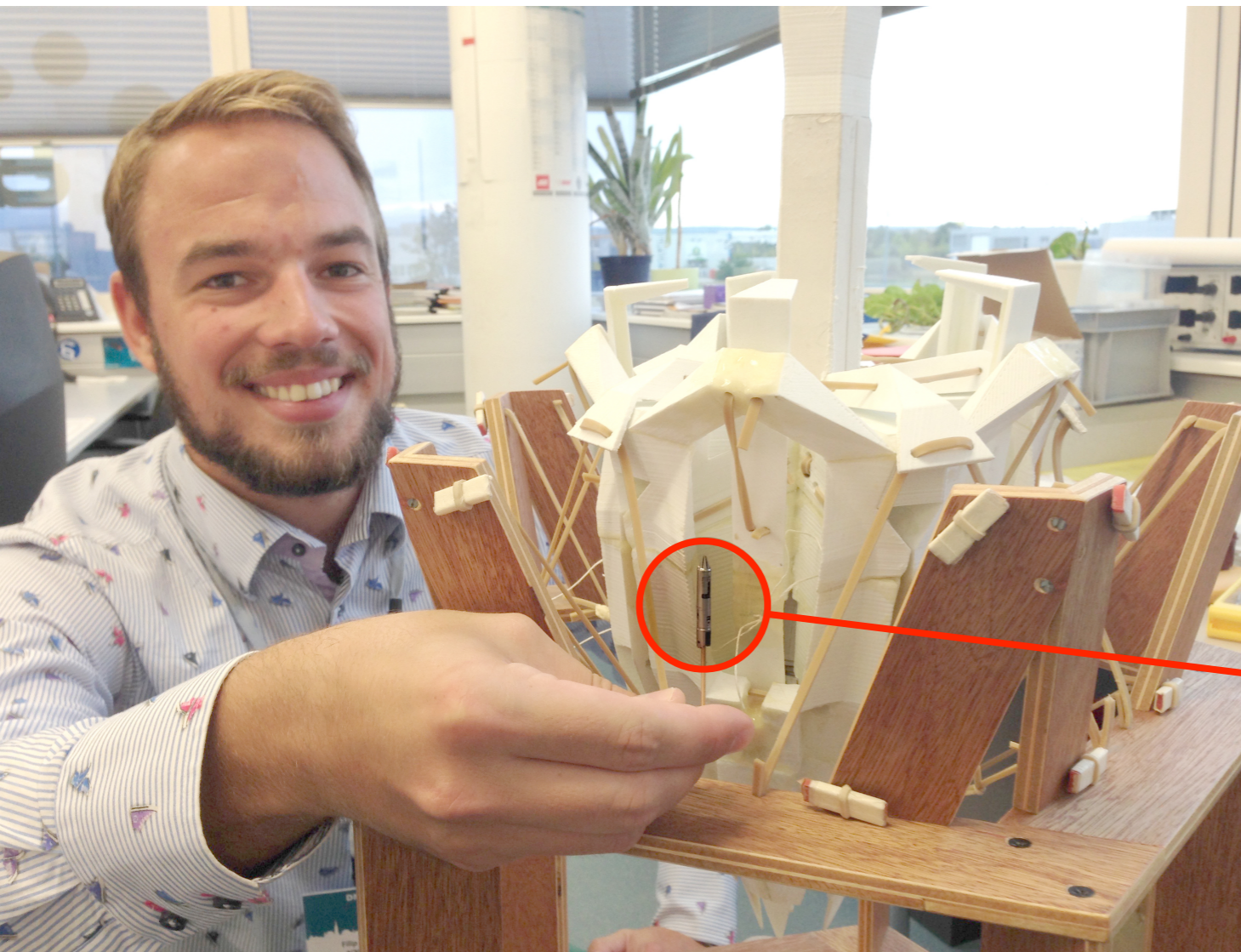

Giorgio Scarpa

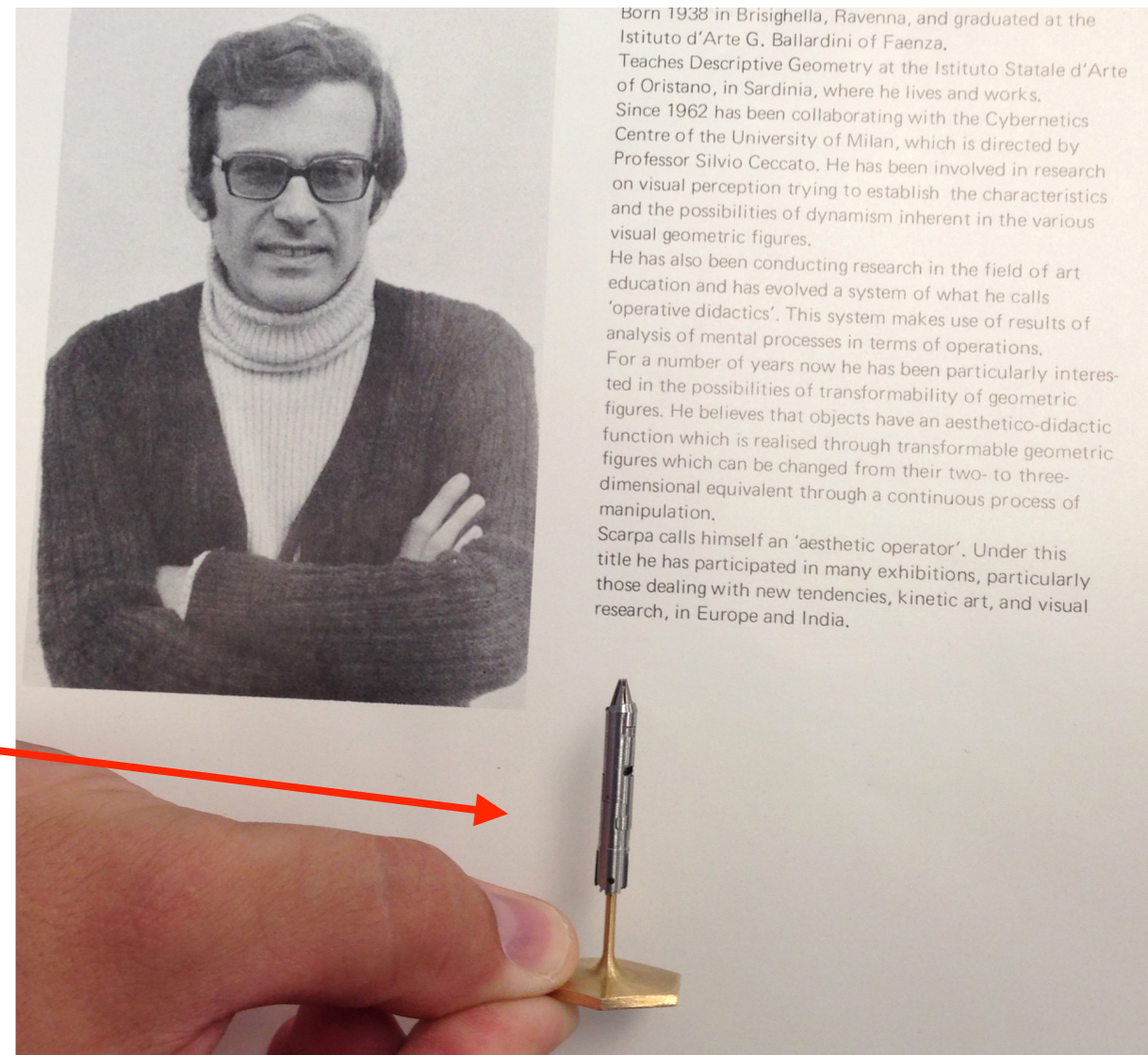

(Jelínek, Smit, Breedveld, UT Delft; ACMIT, Austria, 2014)

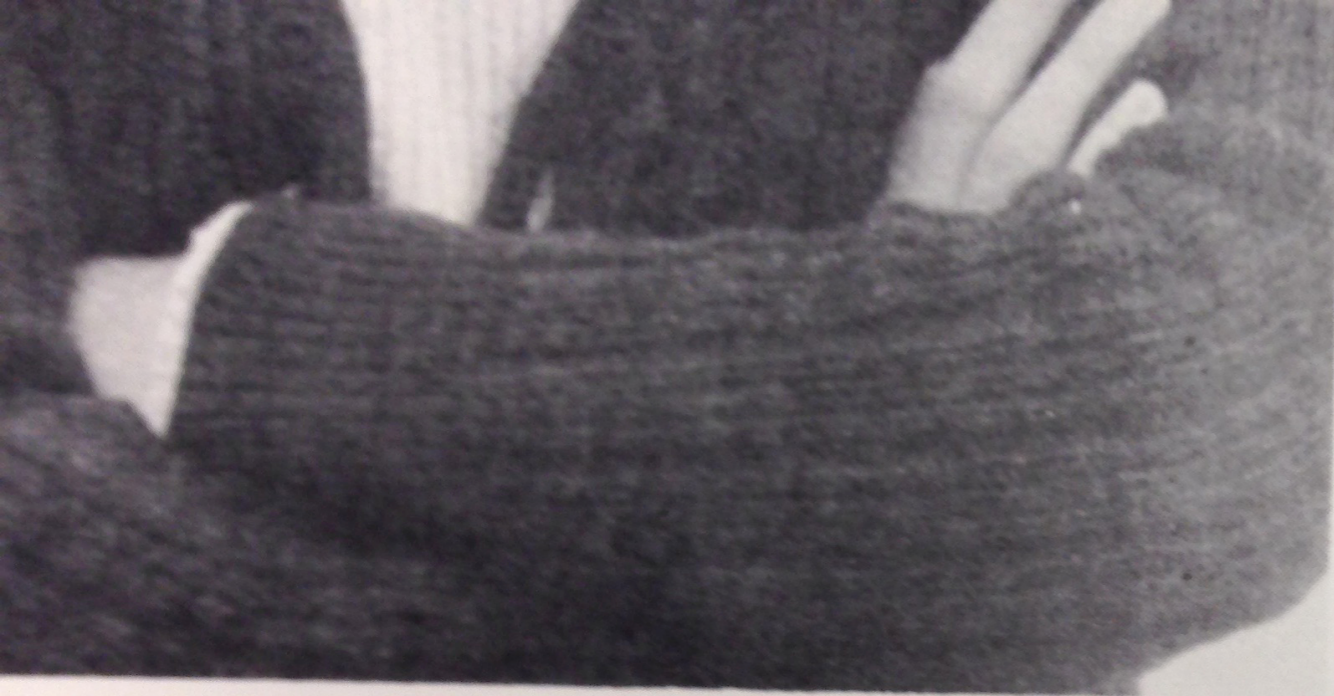

manipulation.
Scarpa calls himself an 'aesthetic operator'
title he has participated in many exhibit
those dealing with new tendencies, kine
research, in E

(Jelínek, Smit, Breedveld, UT Delft;
ACMIT, Austria, 2014)

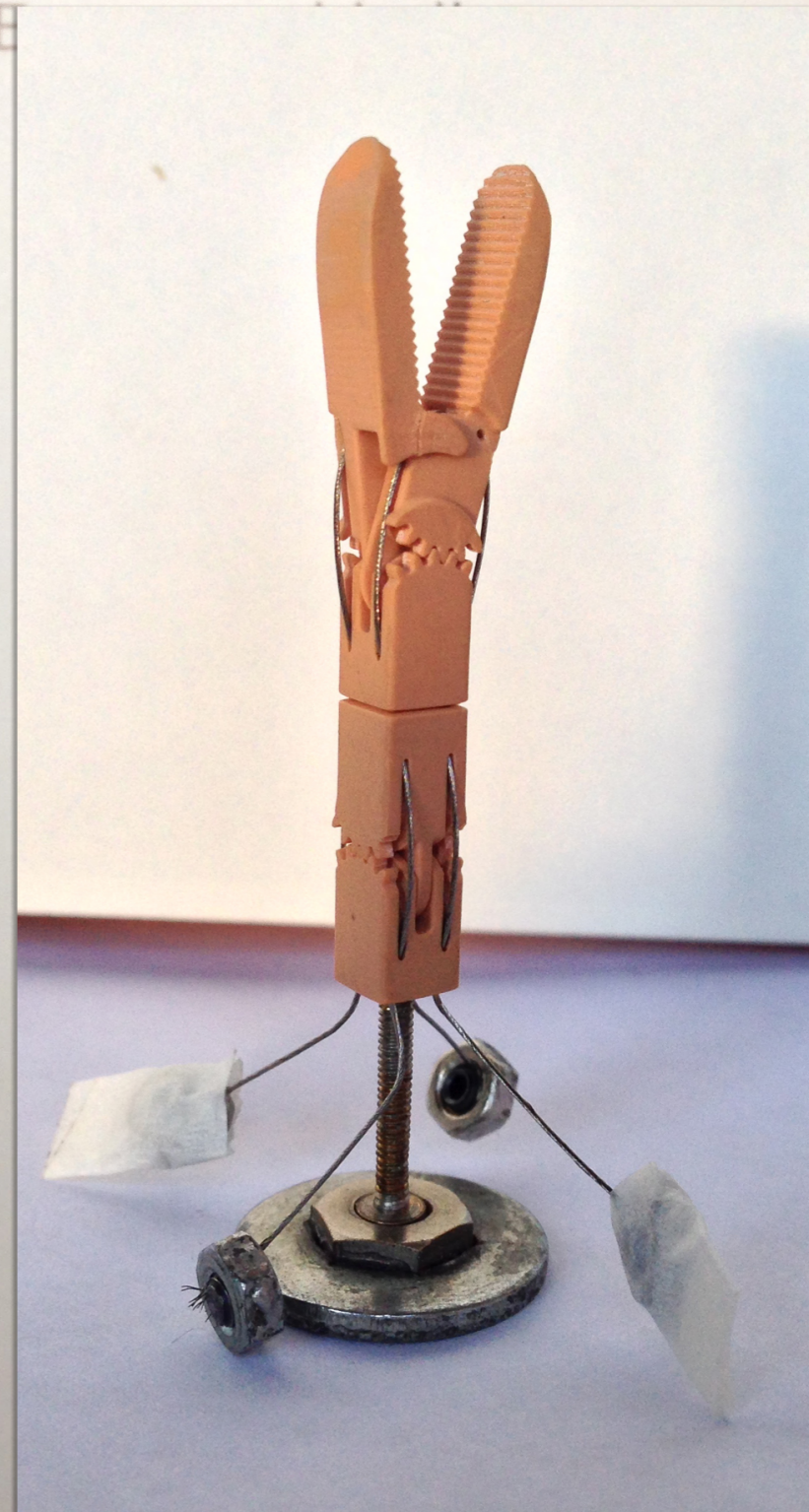



(Jelínek, Smit, Breedveld, UT Delft;
ACMIT, Austria, 2014)

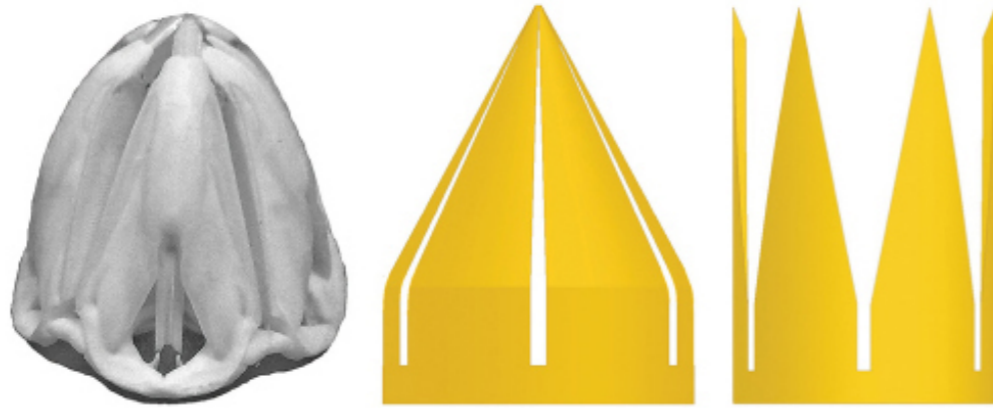
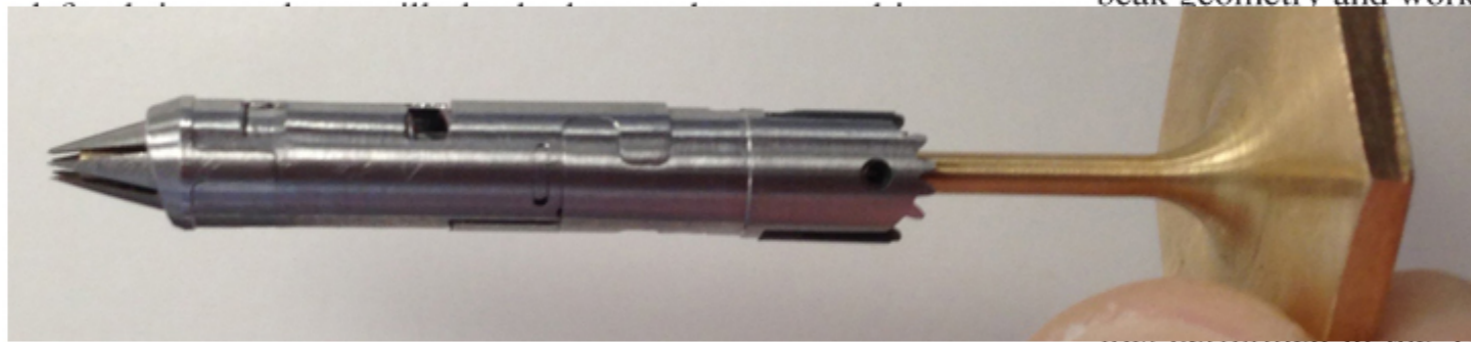

Fig. 4 Sea urchin's chewing organ, Aristotle's lantern—left—providing an inspiration to the biopsy harvester's crown-shaped collapsible cutter (collapsed—center, at rest—right)

round, crown-shaped collapsible cutter was designed (Fig. 4, right), physically resembling Aristotle's lantern and enabling simultaneous tissue incision and enclosure. Since any hinged features would likely lack sturdiness at this scale, not to mention their manufacturing feasibility, the cutter had to be designed thin enough as to allow the collapsibility of the blades and thus the enclosure of the sampled tissue. Six symmetrical blades were chosen as optimal both for manufacturing feasibility and for creating a seemingly straight blade cross section for easy inward bending, while keeping the blade profiles wide and strong enough to prevent outward bending when retracted.



perfect tissue incision with biopsy retrieval in a single tool or procedure. Since accurate, laparoscopic, frontally acting biopsy har-

Propulsion—Pilot Cutter Experiments. The sea urchin's beak geometry and working principle were recognized as essential for the biopsy harvester, combining frontal cutting and tissue enclosure. However, together with its muscle and tendon structure, it was difficult to replicate in a miniature and simple design. It has been decided to modify the crown-shaped cutter so that it would close automatically by force. In order to gain further insight and inspiration into the cutter actuation, an in vitro experiment was performed in the Tensile Testing Lab of our department. Its goal was to find out what forces such a cutter encounters during tissue penetration and to test its cutting capabilities. The crown-

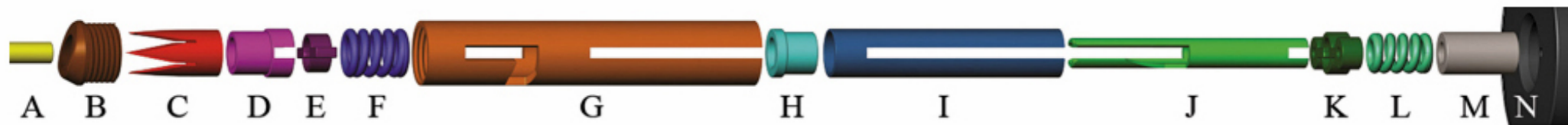

Fig. 6 Exploded view of the spring-loaded biopsy harvester design with its 14 components (A–N), showing their mutual axial alignment

sea urchin's bulky exoskeleton. The beak bites through and encompasses even a very tough material, e.g., corals, by pressing the mutually fitting teeth together by axial translation, due to the basal attachment of the muscle tendons [22,23]. More specifically, Aristotle's lantern is open when protruding outwards and closed when retracted inwards. As demonstrated by Giorgio Scarpa's bionic model of Aristotle's lantern [24,25], by this means, the sea urchin can simultaneously cut off and enclose its food in a seemingly unified and continuous motion. The capability of the simultaneous tissue incision and enclosure by axial translation exactly fits the envisioned biopsy harvester's functionality needs. This is

protocol was followed with the cutting experiments performed on a single piece of chicken breast. The collapsing motion of the cutter blades was not yet taken into account in this experiment, i.e., the cutter stayed open.

The test at e curves measur was, th observi effortle

(Jelínek, Smit, Breedveld, UT Delft; ACMIT, Austria, 2014)

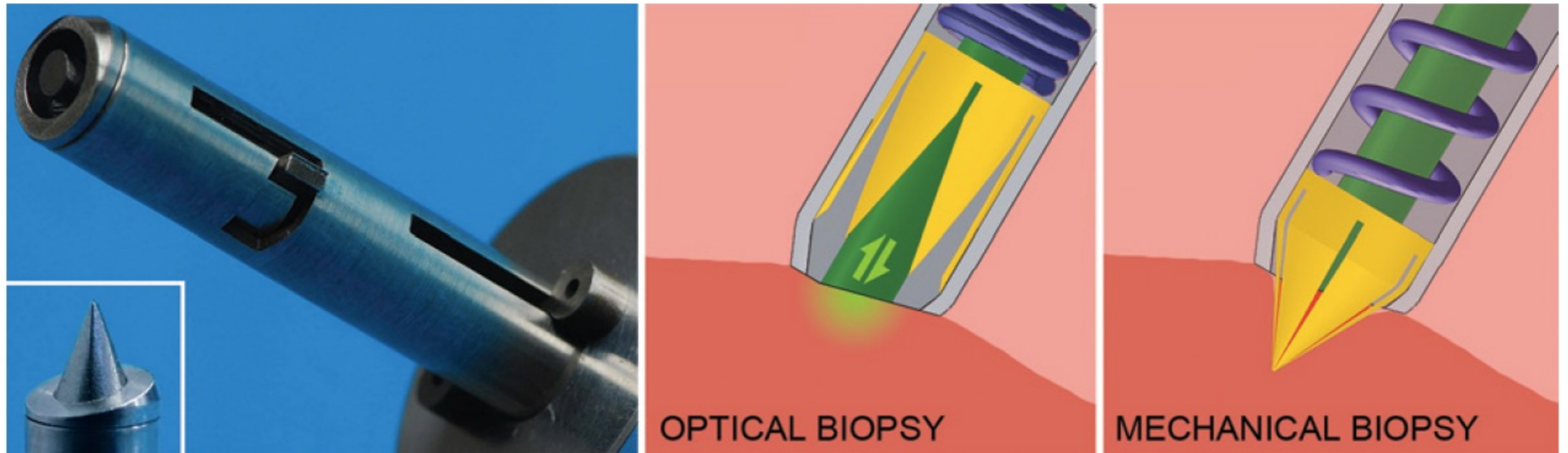
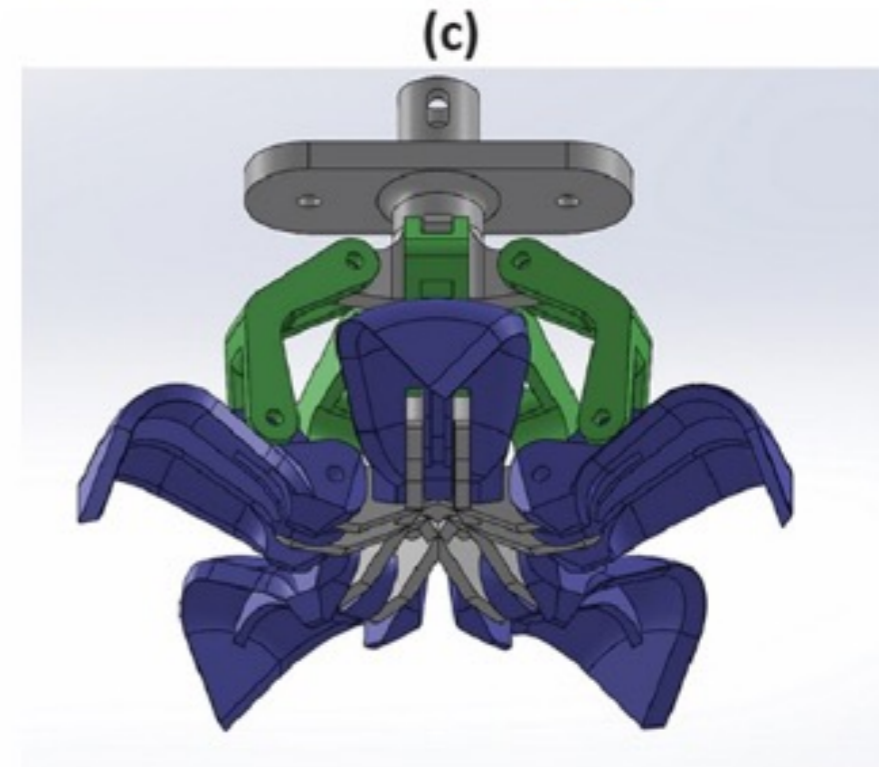
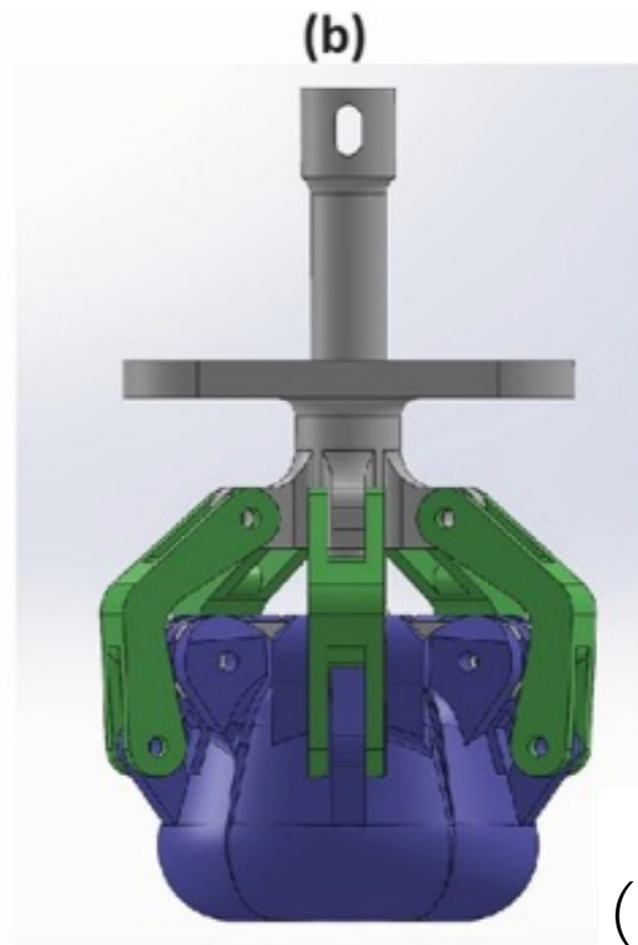
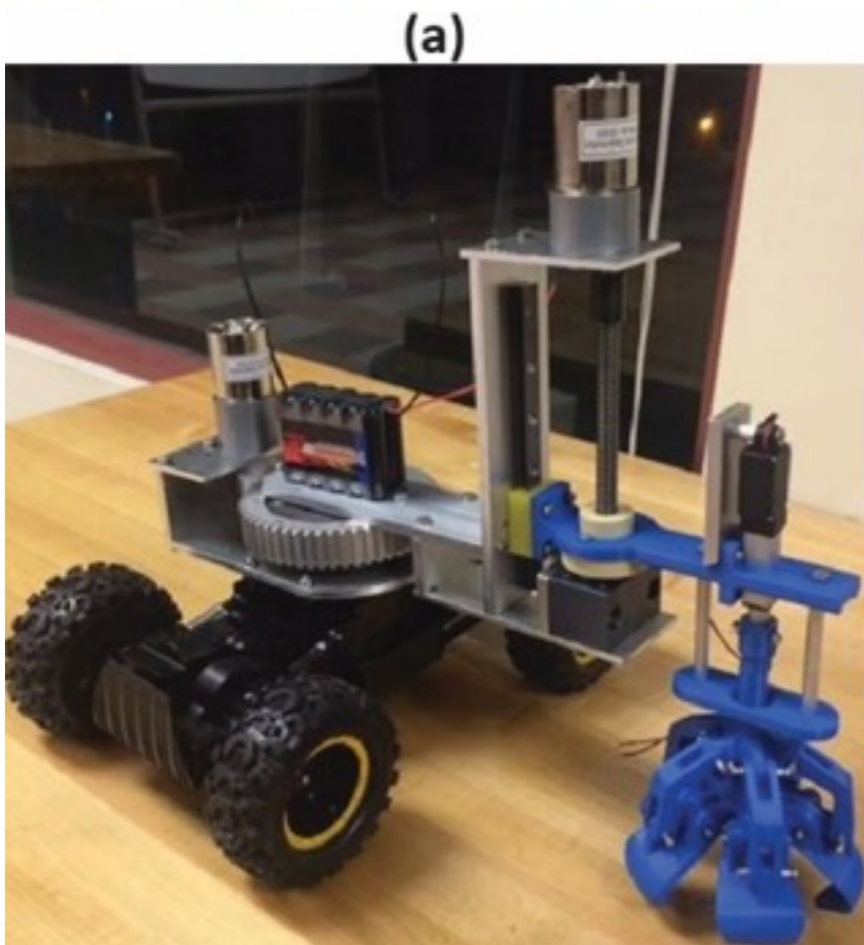
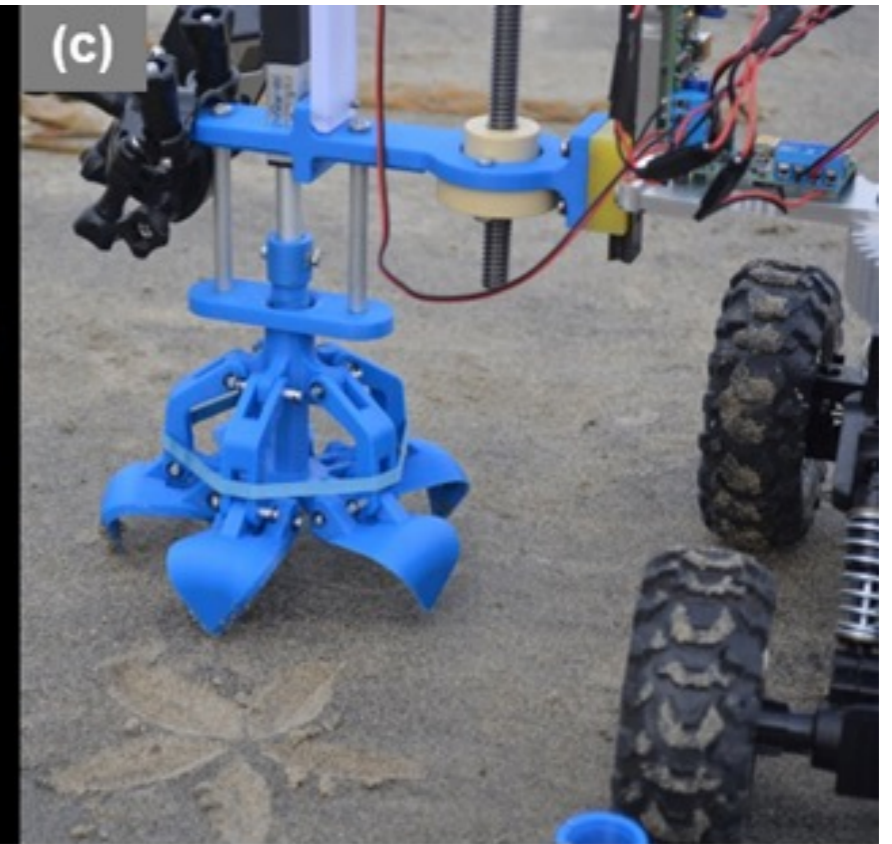
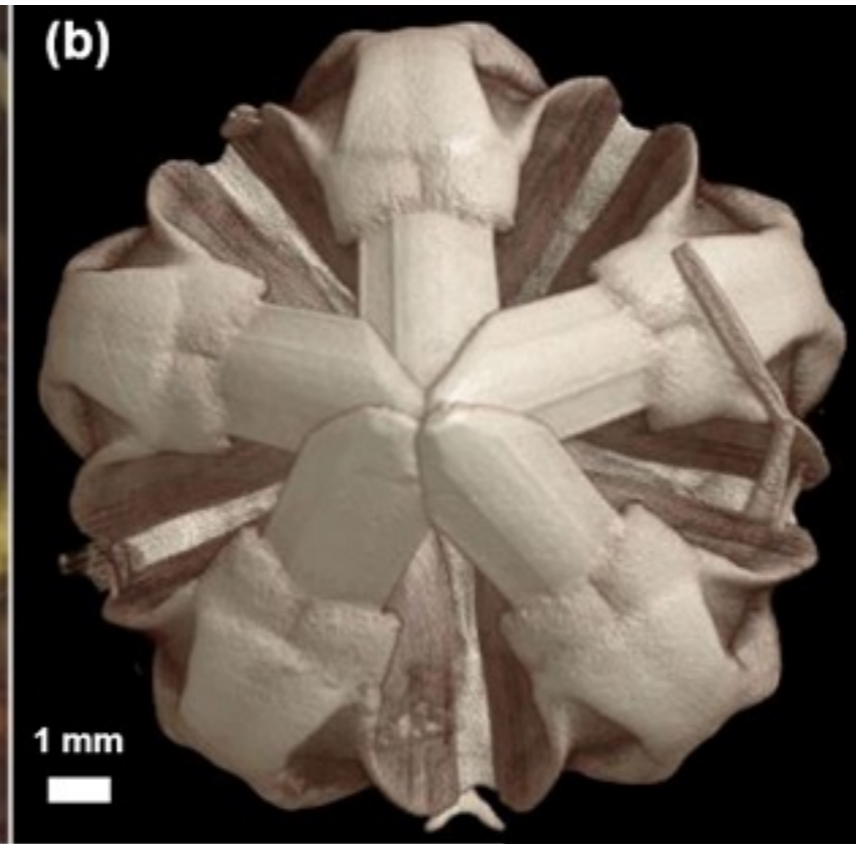
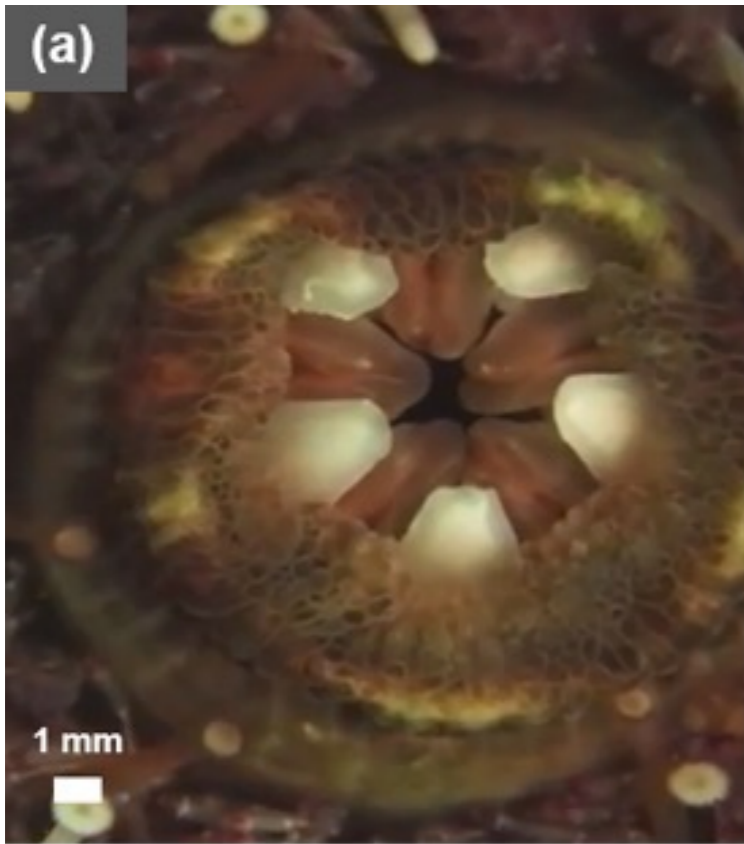
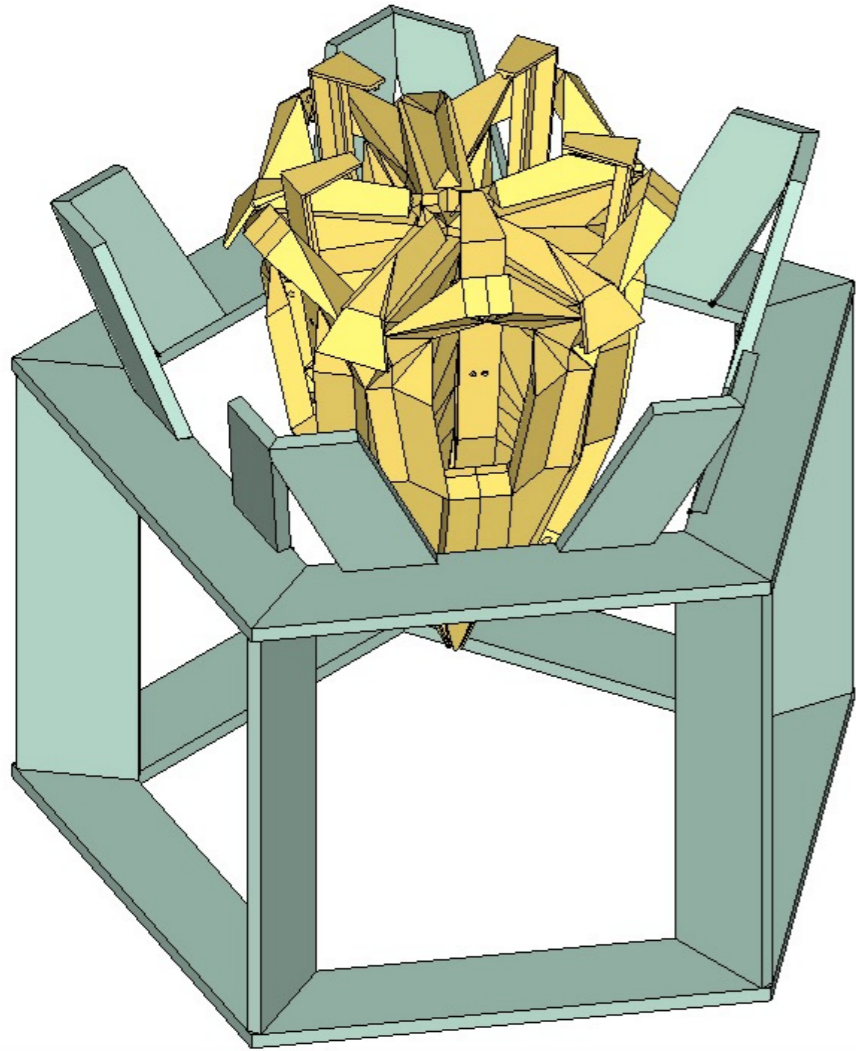

Fig. 2 Keyhole biopsy harvester [6] and its working principle combining optical and mechanical biopsy

(Jelínek, Smit, Breedveld, UT Delft;
ACMIT, Austria, 2014)



(Frank et al, UC San Diego, 2015)



(Trogu – after Scarpa, 2014)

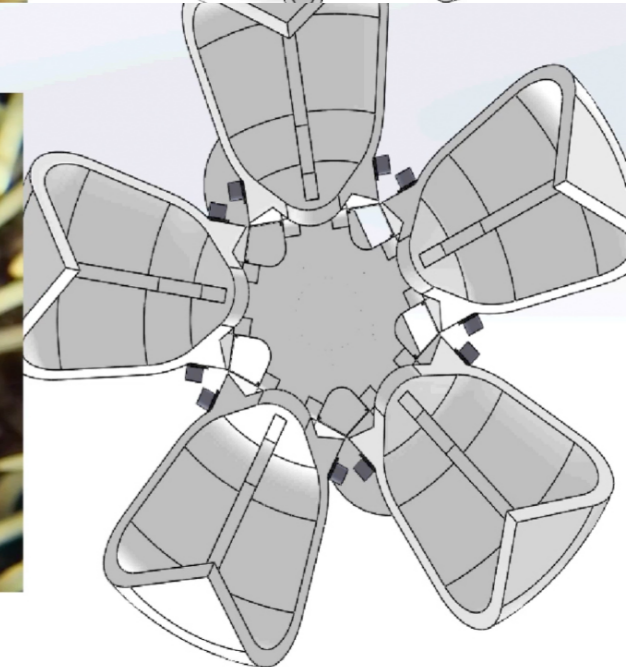
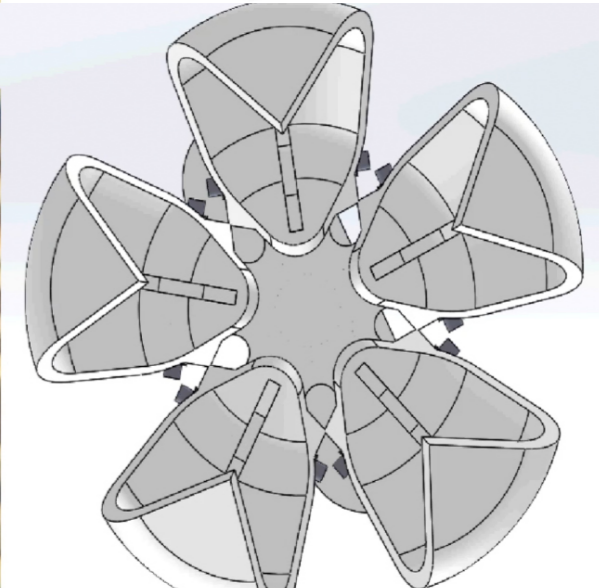
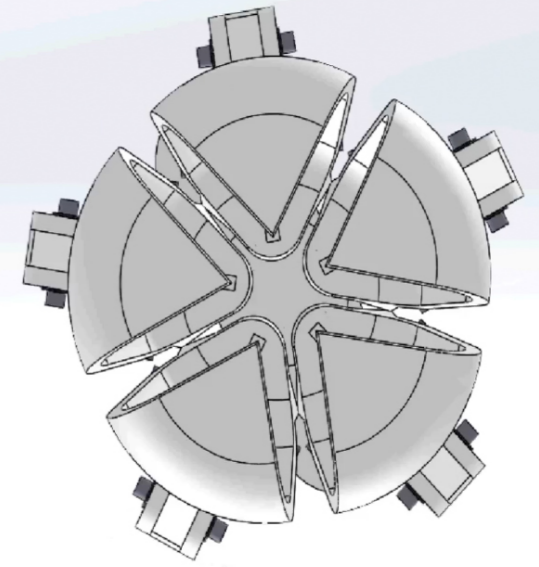

(Frank et al, UC San Diego, 2015)



Foto: Giorgio Cireddu



Nella pagina a fianco, 25 catene ad anello, 150 coppie, 300 moduli, formano questo ordinamento spaziale visto in proiezione orizzontale.

Cristallo di tropomiosina. La microfotografia è una proiezione in un piano di un reticolo tridimensionale costituito da filamenti molecolari connessi trasversalmente e ingranditi 200 000 volte.

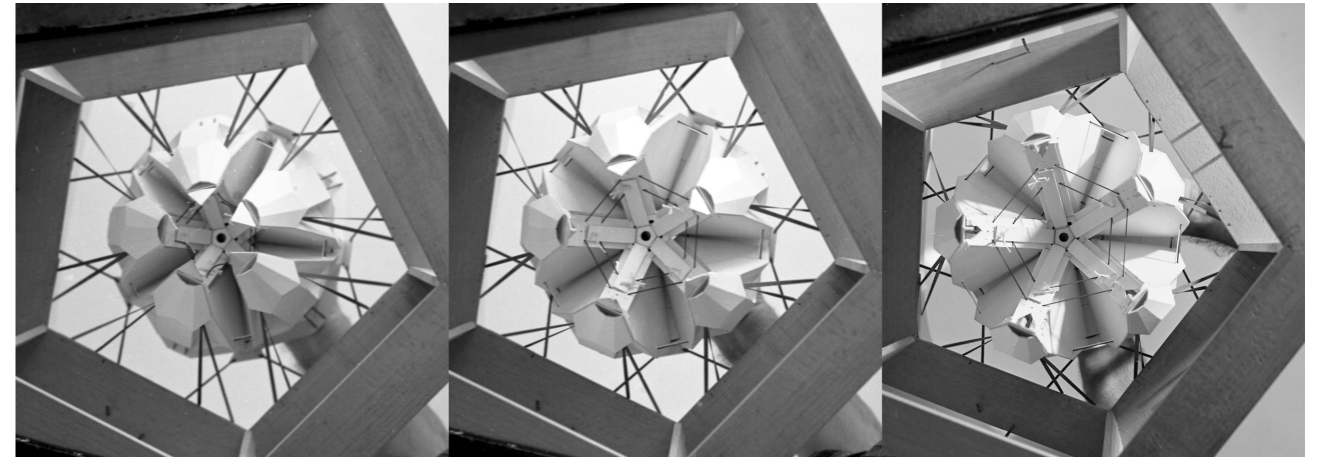
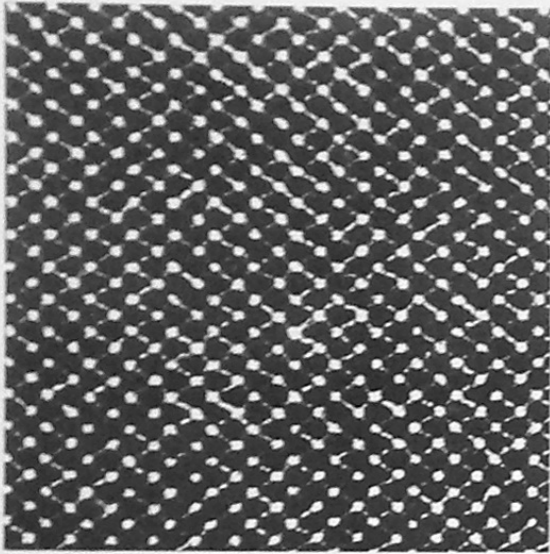
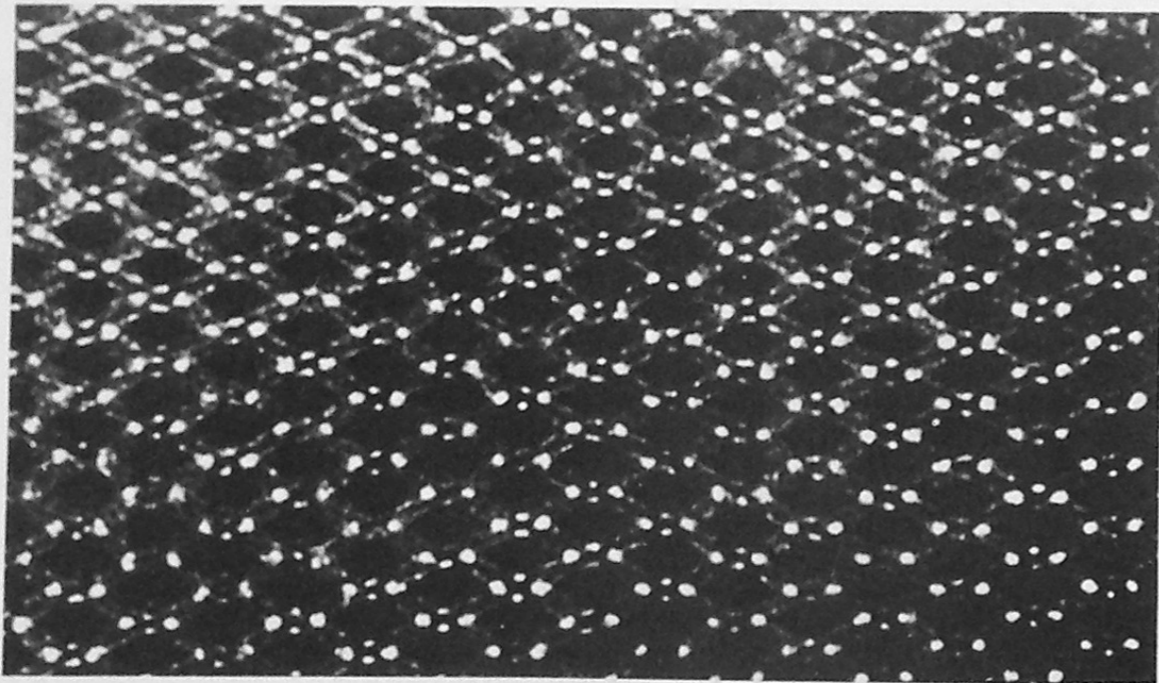

Microfotografia di una rete a doppio rombo di una fibra muscolare.

94

Modelli di geometria rotatoria, pp. 94-95

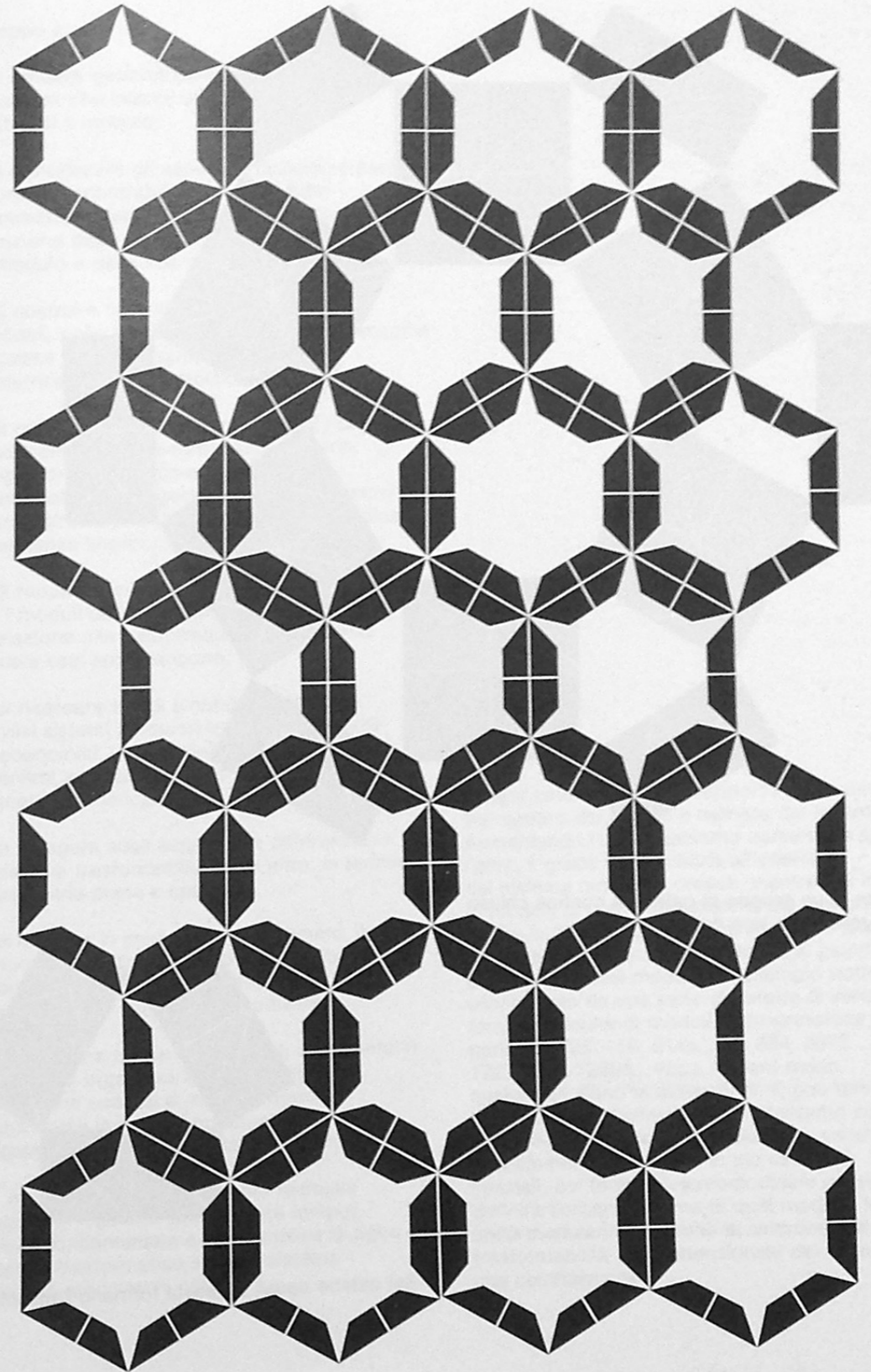

95

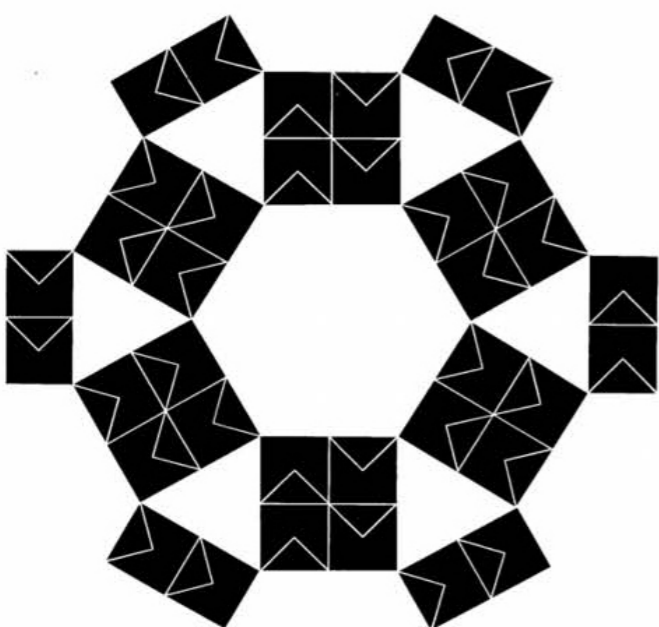
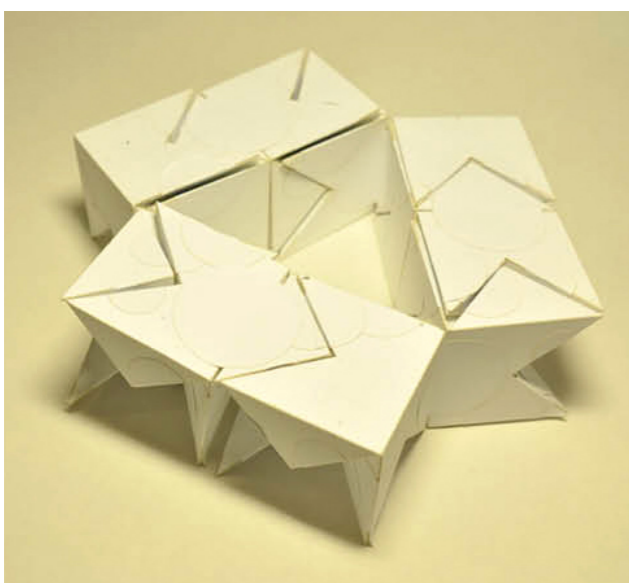

Modelli di
geometria rotatoria, p. 96

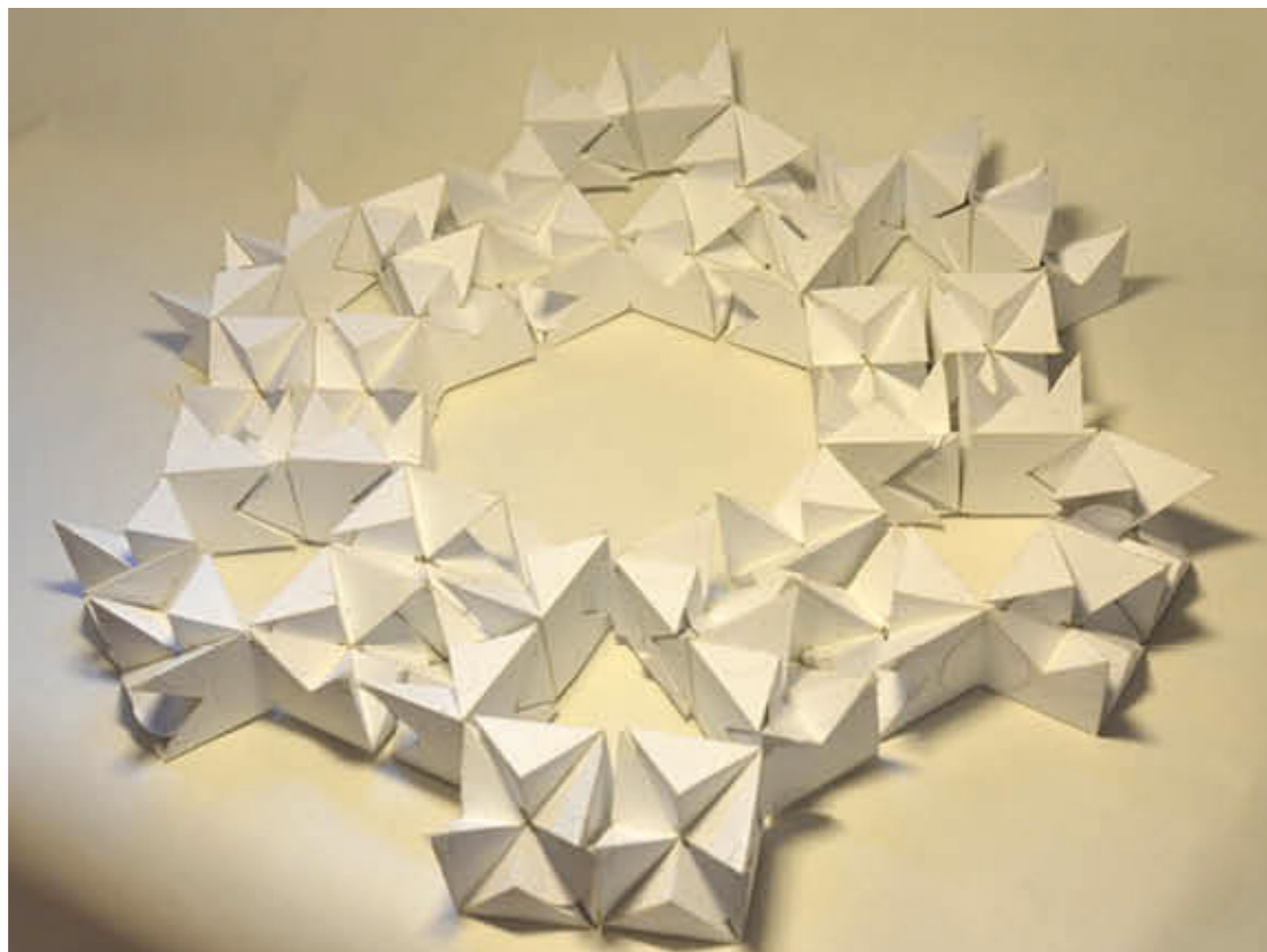

(Trogu & Nies, prova modello, 2015)



Giorgio Cireddu

International Society for Medical Innovation and Technology, iSMIT 2016, Delft, Olanda



Design of Medical Devices DMD EU 2016, Delft, Olanda

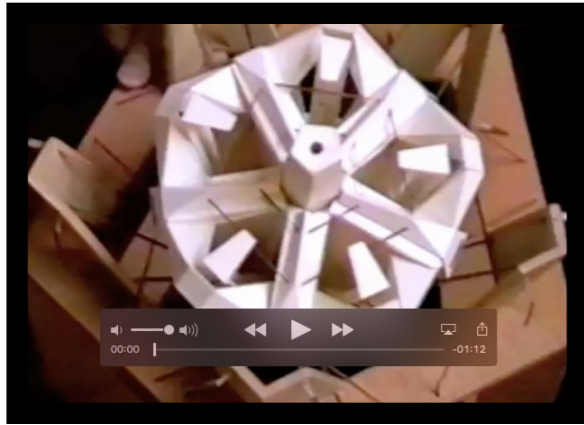

[scarpa lanterna aristotele video](#)



[jelínek UT DELFT dragonflex video](#)



[frank UCSD mars rover video](#)

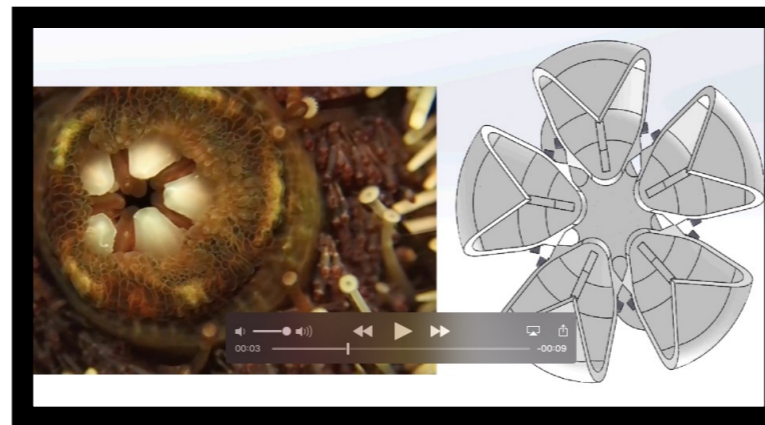

[frank UCSD urchin side-by-side video](#)



[scarpa "poi mi dimentico" video](#)

VIDEO

(Jelínek, Smit, Breedveld, UT Delft;
ACMIT, Austria, 2014)

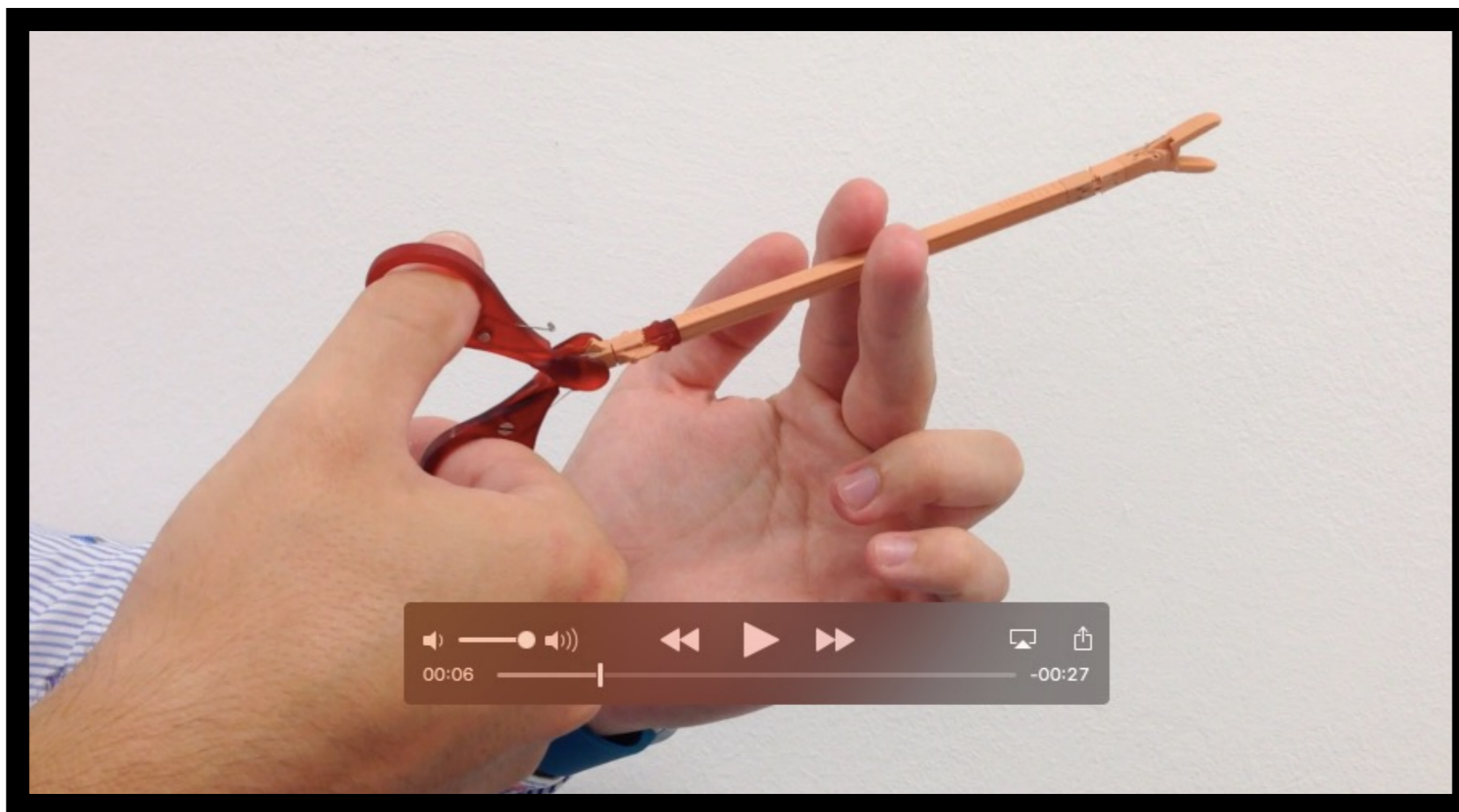

[jelínek UT DELFT dragonflex video](#)

(Frank et al, UC San Diego, 2015)



[frank UCSD mars rover video](#)

(Frank et al, UC San Diego, 2015)

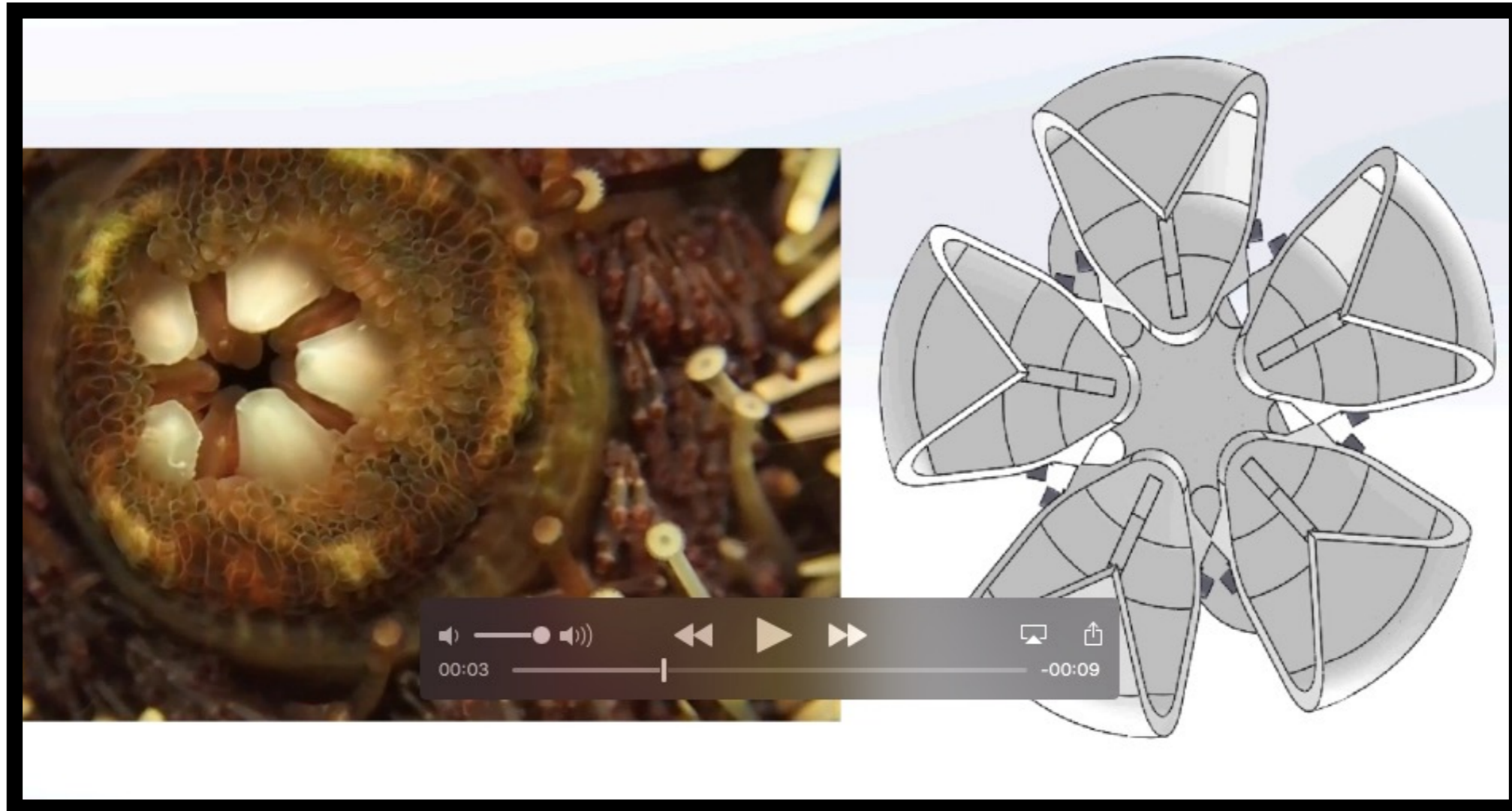

[frank UCSD urchin side-by-side video](#)



[scarpa "poi mi dimentico" video](#)

Prototipo DragonFlex per biopsie

(Jelínek, Smit, Breedveld, UT Delft;
ACMIT, Austria, 2014)



Lanterna di Aristotele e teca del riccio di mare



Lanterna, dente scorrevole, Scarpa, c. 1970. (Trogu, replica, 2015)

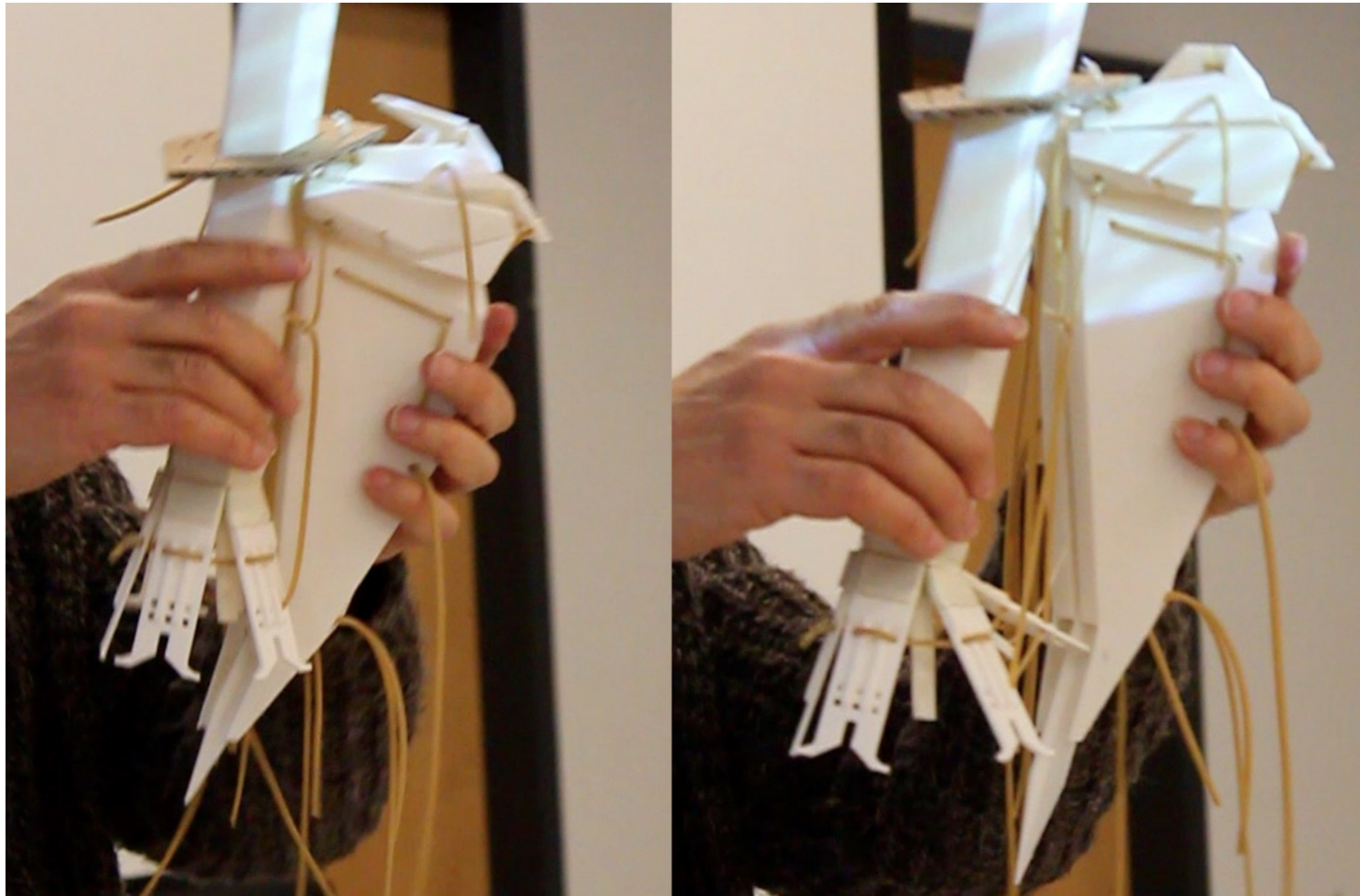

Oggetto cubico trasformabile, Scarpa, 1996.

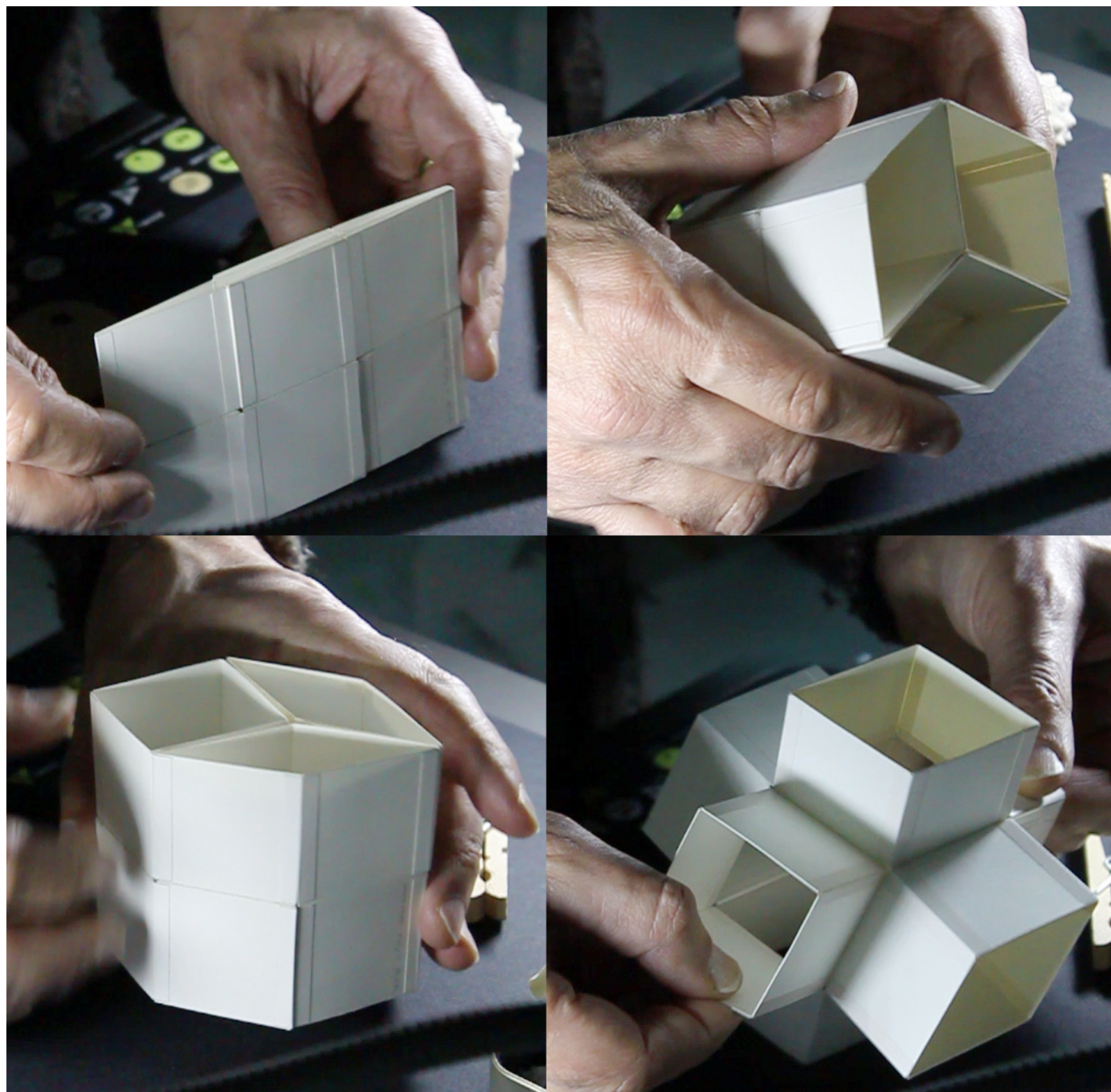

(“Ancient dragon” realizzato da Francesco Trogu su modello e istruzioni di Satoshi Kamiya.)

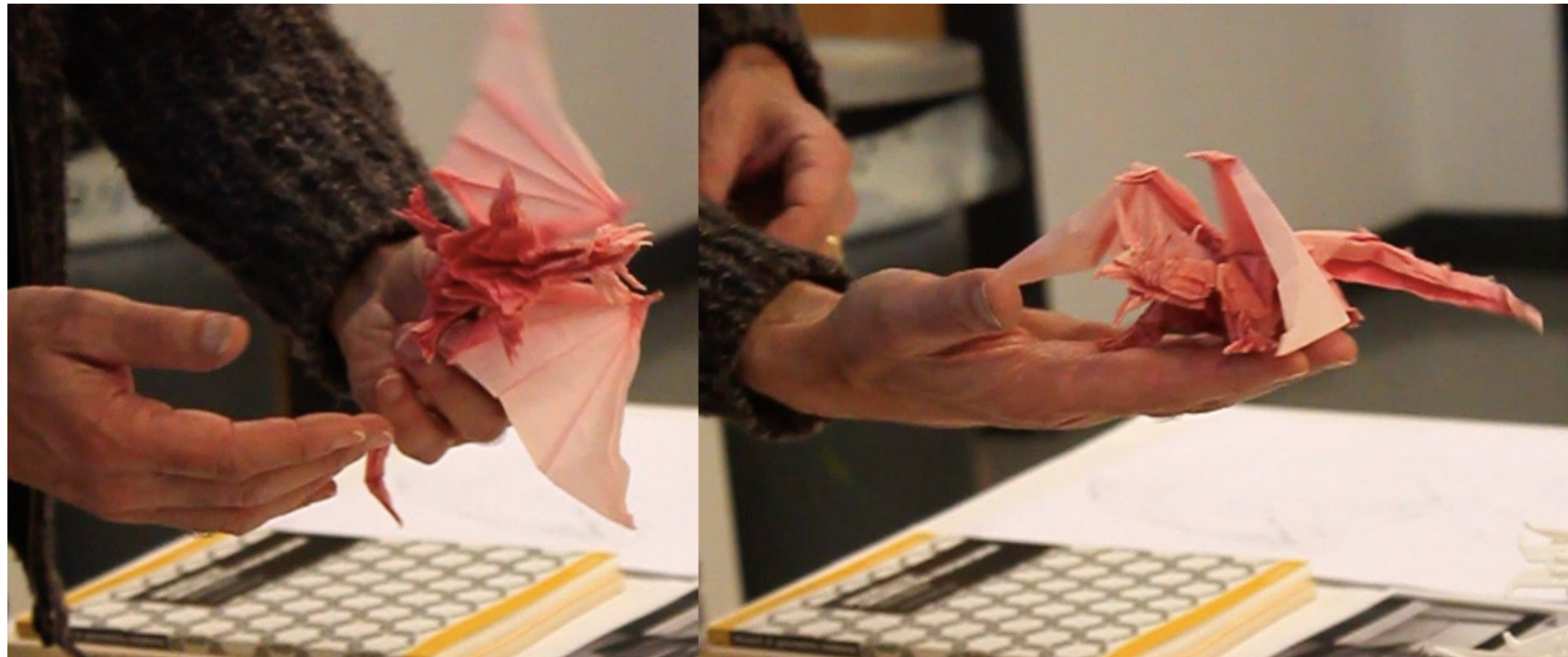

G. Scarpa, Modelli di geometria rotatoria, pp. 66-67.

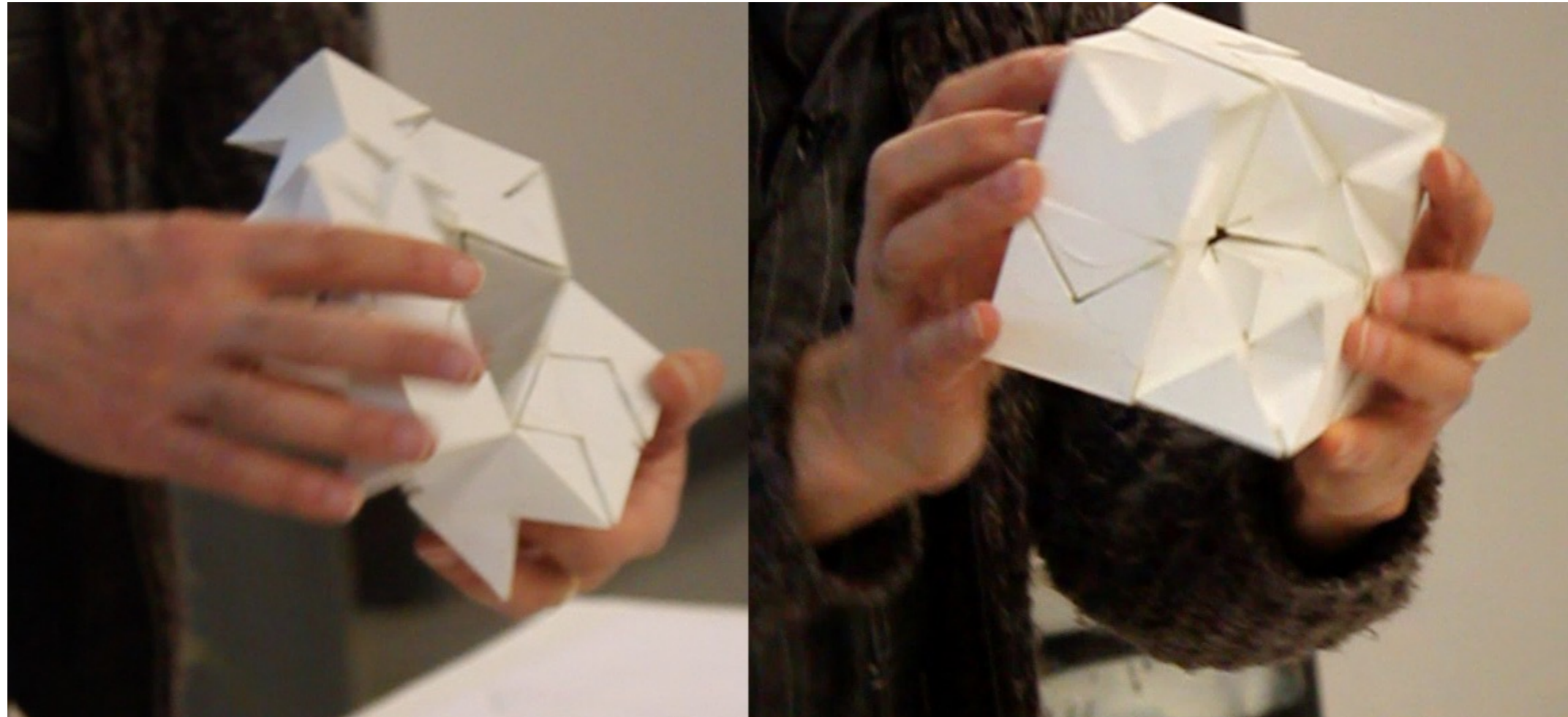

sabato 21 novembre 2015

GLI OGGETTI TRASFORMABILI DI GIORGIO SCARPA

geometria come arte, scienza, gioco

Teatrino del vecchio mercato | convegno

ore 9.30 _ saluti

Alberto Mingotti moderatore

Daniele Meluzzi sindaco del Comune di Castel Bolognese

Licia Tabanelli assessore all'Istruzione

Giovanni Morini assessore alle Attività e ai beni culturali

Vanna Maria Monducci dirigente scolastico dell'Istituto Comprensivo Carlo Bassi

Roberto Ossani direttore dell'ISIA Istituto Superiore per le Industrie Artistiche Faenza

Luigi Neri dirigente scolastico del Liceo Torricelli - Ballardini Faenza

interventi

Claudio Piersanti | Il lavoro di Giorgio Scarpa nel contesto del suo tempo e delle varie discipline

Paolo Pasi | La geometria dello spazio e i registri di rappresentazione semiotica

Simone Cireddu | Io mi ricordo. Sussidiario illustrato di *Giorgiografie* portatili

Germano Zanzani | Giorgio Scarpa all'ISIA

Lorenzo Bocca | Giorgio Scarpa: sperimentazione geometrica e didattica

Pino Trogu | L'attualità della ricerca di Scarpa nell'ambito tecnico-scientifico
videoconferenza da San Francisco

ore 12.00 _ interventi dal pubblico e discussione

Biblioteca comunale Luigi Dal Pane | laboratorio

ore 14.30 - 16.30

Reticoli, moduli, sezioni, geometria rotatoria

laboratorio didattico aperto ai docenti di scuola secondaria di primo e secondo grado

condotto da **Lorenzo Bocca**



COMUNE DI CASTEL BOLOGNESE
Provincia di Ravenna



ISIA
ISTITUTO SUPERIORE PER LE INDUSTRIE ARTISTICHE | FAENZA
DESIGN & COMUNICAZIONE



LICEO TORRICELLI - BALLARDINI FAENZA

Pagina web di riferimento generale sul lavoro di Scarpa.

Giorgio Scarpa
Italian designer, bionics researcher, teacher, and artist.

Profile and videos by **Pino Trogu**, San Francisco State University [trogu at sfsu dot edu]

The short videos below refer to the topics of Scarpa's two books. The first is a bionic study of the mouth apparatus of the sea urchin, also known as Aristotle's Lantern, after the first detailed study of it by the Greek philosopher. The PDF of the book (unpublished draft English translation) is at right. The second shows one of the many "modular" chains described in the rotational geometry book, which focuses on rotational movement as a basic form generating process. Scarpa dissects the five Platonic solids and other solids into chains of hinged triangular pyramids that fold back into their enclosure cells. Both books were published as part of a now out-of-print series called "Design Notebooks", edited by the late Italian designer Bruno Munari. The covers of the books in that series are shown below. The other videos show more topological and bionic studies by Scarpa, including DNA models and studies of muscle structure.

This page was last updated on Tuesday, May 27, 2014.

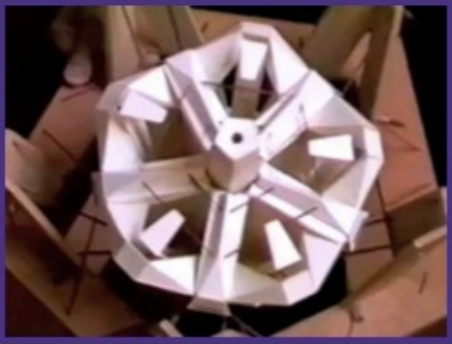

[Bionic Model of Aristotle's Lantern](#)
Video length: 1'-12". Video: Pino Trogu, 1994.

[Bionic Model of Aristotle's Lantern](#)
Video length: 1'-12".

Citations:
[Bioinspired Spring-Loaded Biopsy Harvester — Experimental Prototype Design and Feasibility Tests](#)
Filip Jelínek, Gerwin Smit and Paul Breedveld
Journal of Medical Devices 8(1), March 2014.

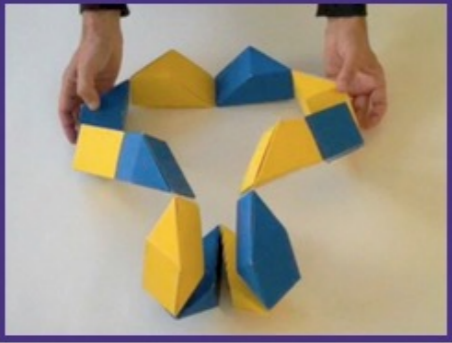

Click image to download PDF of complete Bionic Models book. Unpublished English translation of Italian Edition: Modelli di Bionica, 1985.
Translated by Pino Trogu. 122 pages
File size: 38MB.

Click [here](#) to download PDF of pages 3-20 and 60-74 only.
File size: 13MB.

[Hexahedral Chain](#)
Video length: 1'-12"

CONFERENCE PAPER (PDF 5MB)
[Rotational Geometry as a Teaching Tool: Applying the Work of Giorgio Scarpa \(Article\)](#)
DRS // CUMULUS 2013
2nd International Conference for Design Education Researchers
Oslo, 14–17 May 2013

POSTER (36"x48" PDF 7MB)
[Rotational Geometry as a Teaching Tool: Applying the Work of Giorgio Scarpa \(Poster\)](#)
Faculty Research And Creative Activities

Click image to download PDF of complete Geometry Models book. Unpublished English translation of Italian Edition: Modelli di Geometria Rotatoria, 1978.

Click [here](#) to download PDF of a sample of Mary Vieira's student work from the Kunstgewerbeschule, Basel, 1966-1967.
Various sections of the cube.

[Cubic chain of 24 modules. Designed by Florence Yuen. \(PDF\)](#) San Francisco State University, Fall 2010. Instructor: Pino Trogu. The design of the chain follows the principles and methods outlined in "Models of Rotatory Geometry", by Giorgio Scarpa.

<http://online.sfsu.edu/trogu/scarpa/>

THANK YOU!

PINO TROGU – SAN FRANCISCO STATE UNIVERSITY, USA

GIORGIO SCARPA

L'ATTUALITÀ DELLA RICERCA DI SCARPA
NELL'AMBITO TECNICO-SCIENTIFICO



Giorgio Scarpa
Pino Trogu
Castel Bolognese, 1988

PDF of slides and videos:

http://www.trogu.com/Documents/conference/2015_castelbolognese

Contact

trogu@sfsu.edu

[go to first slide](#)